



78M05 Features

- Output Current of 0.5A
- Output transistor safe area protection
- No external components
- Package: TO252

78M05 General Description

78M05 is three-terminal positive regulators. One of these regulators can deliver up to 0.5A of output current. When used as a replacement for a

Zener diode-resistor Combination, an effective improvement in output impedance can be obtained, together with lower quiescent current.

78M05 Pin Configuration

TO252 (Top View)

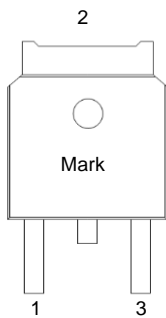

PIN NO.	PIN NAME	FUNCTION
1	VIN	Input voltage pin
2	GND	Ground pin
3	VOUT	Output voltage pin



78M05 Block Diagram

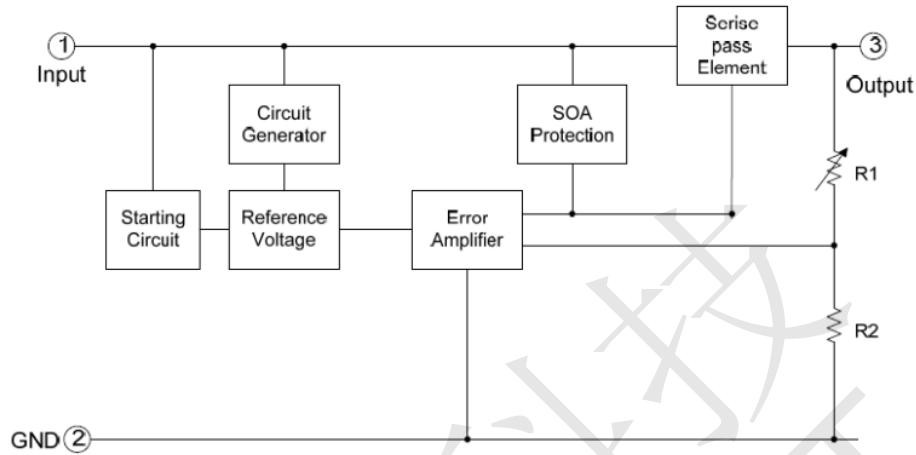

78M05 Absolute Maximum Ratings (Ta=25°C)

Parameter	Rating	Unit
Input supply voltage: VIN	40	V
MAX. Output current:Iout	500	mA
MAX Power:Pmax	1	W
Maximum junction temperature:Tj	-25~125	°C
Storage temperature:Tstr	-55~125	°C
Soldering temperature and time	+260(Recommended 10S)	°C

Note: The absolute maximum ratings are rated values exceeding which the product could suffer physical damage. These values must therefore not be exceeded under any conditions.



78M05 Electrical Characteristics

(C_{in}=0.33uF, C_o=0.1uF, 0≤T_j≤125℃, unless otherwise noted)

Parameter	Symbol	Conditions	Min.	Typ.	Max.	Unit
Input Voltage	V _{IN}	-	-	35	-	V
Output Voltage	V _{out}	I _o =40mA, V _{IN} =10V	0.964v _{out}	V _{OUT}	1.036v _{out}	V
		I _o =1mA~40mA V _{IN} =7V~18V	0.96v _{out}	V _{OUT}	1.04v _{out}	
		I _o =10mA V _{IN} =10V	0.95v _{out}	V _{OUT}	1.05v _{out}	
Line Regulation	LNR	V _{IN} =7V~18V, I _o =40mA	-150	-	150	mV
		V _{IN} =8V~18V, I _o =40mA	-100	-	100	
Load Regulation	LDR	V _{IN} =10V, I _o =1mA~100mA	-60	-	60	mV
		V _{IN} =10V, I _o =1mA~40mA	-30	-	30	
Output Current	I _{out}	V _{IN} =7.0V, V _{OUT} =5.0v	-	500	-	mA
Dropout Voltage	V _{DIF}	T _j =25℃, I _o =500mA	-	1.7	-	V
Quiescent Current	I _q	V _{IN} =10V	-	1.5	--	mA
Quiescent Current Change	ΔI _q	V _{IN} =8V~18V, I _o =40mA	-1.5	-	1.5	mA
		V _{IN} =10V, I _O U _T =1mA~40mA,	-0.1	-	0.1	

LNR: Line Regulation. The change in output voltage for a change in the input voltage. The measurement is made under conditions of low dissipation or by using pulse techniques such that the average chip temperature is not significantly affected.

LDR: Load Regulation. The change in output voltage for a change in load current at constant chip temperature.



78M05 Typical Application

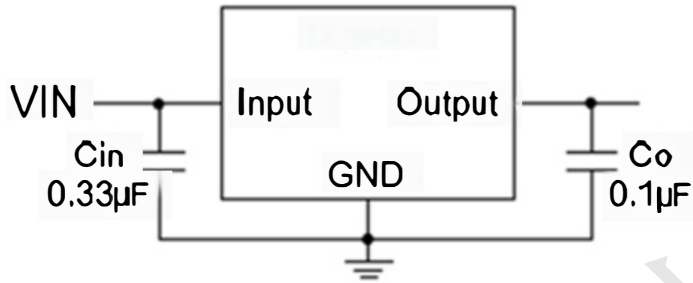

Fig.1 Fixed Output Regulator

矽源特科技
ChipSourceTek



78M05 Package Information

TO-252-2L PACKAGE OUTLINE DIMENSIONS

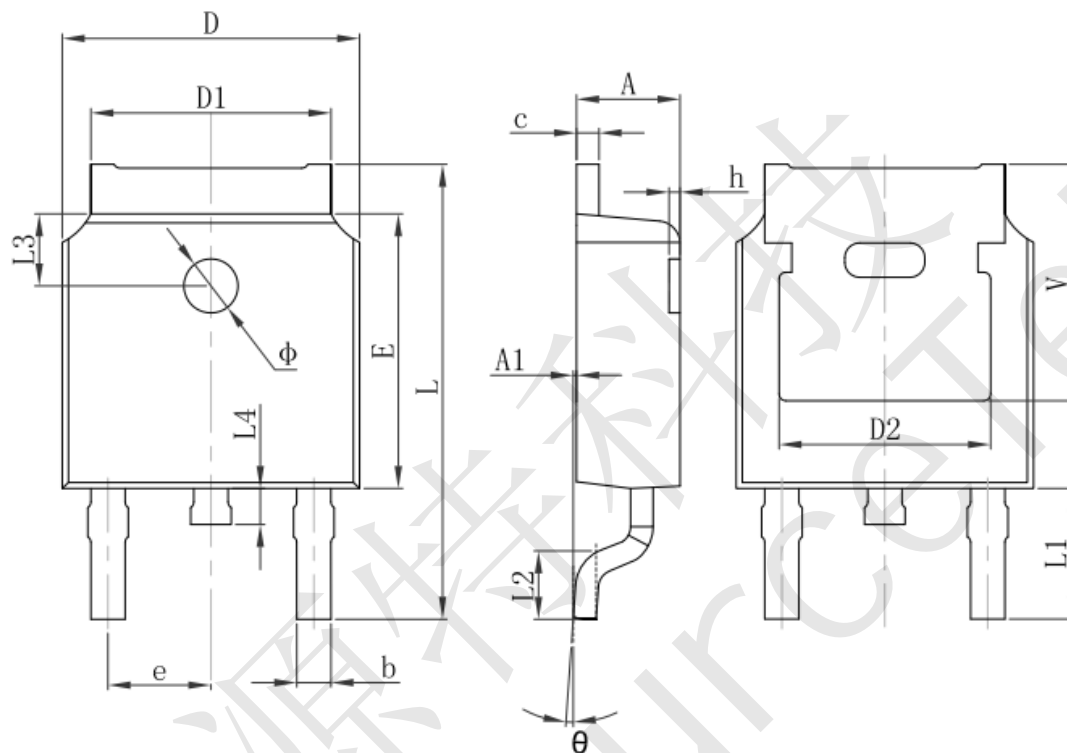

Symbol	Dimensions In Millimeters		Dimensions In Inches	
	Min.	Max.	Min.	Max.
A	2.200	2.400	0.087	0.094
A1	0.000	0.127	0.000	0.005
b	0.660	0.860	0.026	0.034
c	0.460	0.580	0.018	0.023
D	6.500	6.700	0.256	0.264
D1	5.100	5.460	0.201	0.215
D2	4.830 REF.		0.190 REF.	
E	6.000	6.200	0.236	0.244
e	2.186	2.386	0.086	0.094
L	9.800	10.400	0.386	0.409
L1	2.900 REF.		0.114 REF.	
L2	1.400	1.700	0.055	0.067
L3	1.600 REF.		0.063 REF.	
L4	0.600	1.000	0.024	0.039
Φ	1.100	1.300	0.043	0.051
θ	0°	8°	0°	8°
h	0.000	0.300	0.000	0.012
V	5.350 REF.		0.211 REF.	