



24V, 500mA Low Dropout Voltage Linear Regulator

AC24 General Description

The AC24 series are a group of low-dropout (LDO) voltage regulators offering the benefits of wide input voltage range, low dropout voltage, low power consumption, and miniaturized packaging.

Quiescent current of only 1.5µA makes these devices ideal for powering the battery-powered, always-on systems that require very little idle-state power dissipation to a longer service life.

The AC24 series of linear regulators are stable with the ceramic output capacitor over its wide input range from 2V to 24V and the entire range of output load current (0mA to 500mA).

AC24 Features

- 1.5µA Ground Current at no Load
- ±2% Output Accuracy
- 500mA Output Current
- Wide Operating Input Voltage Range: 2V to 24V
- Dropout Voltage: 0.35V at 100mA / V_{OUT} 5V
- Support Fixed Output Voltage 1.8V, 3.3V, 5V
- Stable with Ceramic or Tantalum Capacitor
- Current Limit Protection
- Over-Temperature Protection
- SOT-23-3, SOT-23-5, SOT-89-3 Packages Available

AC24 Applications

- Portable, Battery Powered Equipment
- Low Power Microcontrollers
- Laptop, Palmtops and PDAs
- Wireless Communication Equipment
- Audio/Video Equipment
- Car Navigation Systems
- Industrial Controls
- Weighting Scales
- Meters
- Home Automation

AC24 Pin Configurations

SOT-23-5 (R-Type)



SOT-23-3



SOT-23-5

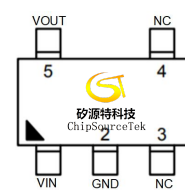

SOT-89-3

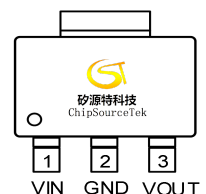

SOT-89-3 (L-Type)



SOT-89-3 (R-Type)

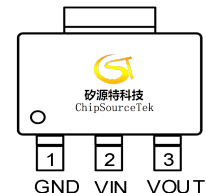



24V, 500mA Low Dropout Voltage Linear Regulator

AC24 Ordering Information

AC24--**AA****BB**

Designator	Description	Symbol	Description
AA	Output Voltage	18	V _{OUT} = 1.8V
	
	
		33	V _{OUT} = 3.3V
		50	V _{OUT} = 5.0V
BB	Package type	GV	SOT-23-3
		GB/GBR	SOT-23-5
		GX	SOT-89-3
		GXL	SOT-89-3 (L-Type)
		GXR	SOT-89-3 (R-Type)

Special Request: Any Voltage between 1.8V and 5V under specific business agreement

AC24 Description of Functional Pins

Pin No					Pin Name	Pin Function
SOT-23-3	SOT23-5 R	SOT-89-3	SOT-89-3 (L-Type)	SOT-89-3 (R-Type)		
1	2	2	2	2	1	GND Ground
2	5	5	3	1	3	VOUT Output of the Regulator
3	1	1	1	3	2	VIN Input of Supply Voltage.
	3,4	4				NC No Internal Connection.
		3				CE Enable Control Input.



24V, 500mA Low Dropout Voltage Linear Regulator

AC24 Typical Application Circuits

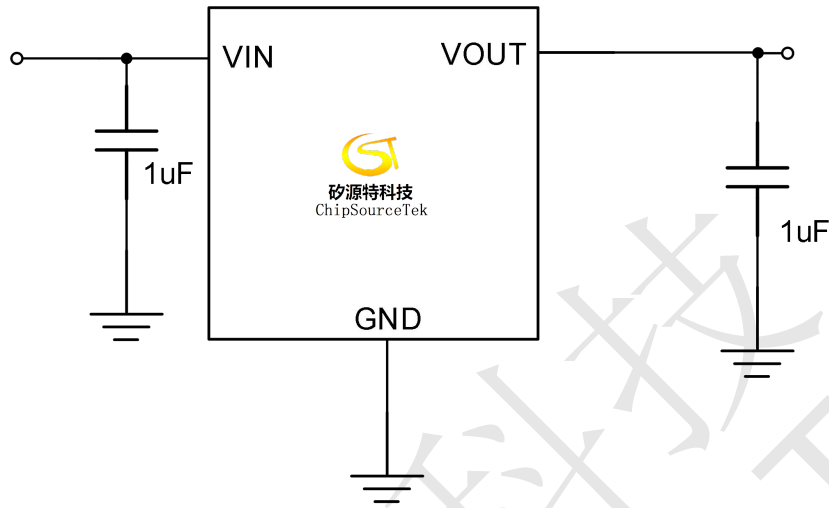
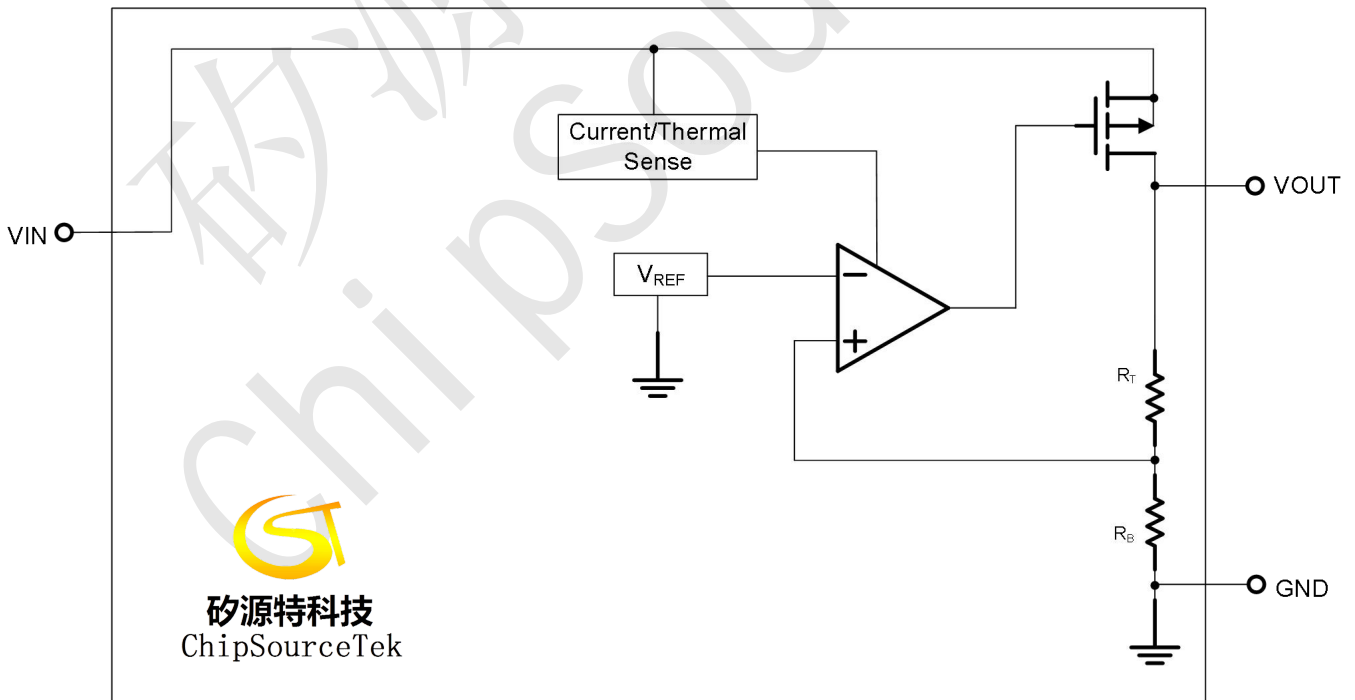

Figure 1: Application circuit of Fixed V_{OUT} LDO

AC24 Function Block Diagram





24V, 500mA Low Dropout Voltage Linear Regulator

Absolute Maximum Ratings (Note 1)

VIN to GND -----	-0.3V to 28V
VOUT to GND	
AC24-18,AC24-33,AC24-50-----	-0.3V to 6.0V
VOUT to VIN -----	-28V to 0.3V
Package Thermal Resistance (Note 2)	
SOT-23-5, SOT-23-3, θ_{JA} -----	200 °C /W
SOT-89-3, θ_{JA} -----	120 °C /W
Lead Temperature (Soldering, 10 sec.) -----	260 °C
Junction Temperature -----	150 °C
Storage Temperature Range -----	-40 °C to 150 °C
ESD Susceptibility	
HBM -----	2KV
MM -----	200V

Recommended Operating Conditions

Input Voltage VIN -----	2.0V to 24V
Junction Temperature Range -----	-40 °C to 125 °C
Ambient Temperature Range -----	-40 °C to 85 °C



24V, 500mA Low Dropout Voltage Linear Regulator

AC24 Electrical Characteristics

($V_{IN} = 15V$, $V_{EN} = 5V$, $T_A = 25^\circ C$ unless otherwise specified)

Parameter	Symbol	Test Conditions	Min	Typ	Max	Unit
Supply Voltage	V_{IN}		2	--	24	V
DC Output Voltage Accuracy		$I_{LOAD} = 0.1mA$	-2		2	%
Dropout Voltage ($I_{LOAD} = 100mA$)	V_{DROP}	$V_{OUT} \geq 5V$	--	0.35		V
	$V_{DROP_3.3V}$	$V_{OUT} = 3.3V$		0.42		
	$V_{DROP_1.8V}$	$V_{OUT} = 1.8V$		0.5		
Ground Current ($I_{LOAD} = 0mA$)	I_Q	$V_{OUT} = 5V$		2.2		μA
Line Regulation	Δ_{LINE}	$I_{LOAD} = 1mA$, $5 \leq V_{IN} \leq 30V$	--	0.3		%
Load Regulation	Δ_{LOAD}	$1mA \leq I_{LOAD} \leq 0.2A$		0.1		%
Output Current Limit	I_{LIM}	$V_{OUT} = 0$	501	700		mA
Power Supply Rejection Ratio	PSRR	$V_{OUT} = 5V$, $I_{LOAD} = 1mA$, $V_{IN} = 12V$, $f = 100Hz$		70		dB
Thermal Shutdown Temperature	T_{SD}	$I_{LOAD} = 10mA$	--	160	--	$^\circ C$
Thermal Shutdown Hysteresis	ΔT_{SD}		15			$^\circ C$

Note 1. Stresses beyond those listed "Absolute Maximum Ratings" may cause permanent damage to the device. These are stress ratings only, and functional operation of the device at these or any other conditions beyond those indicated in the operational sections of the specifications is not implied. Exposure to absolute maximum rating conditions may affect device reliability.



24V, 500mA Low Dropout Voltage Linear Regulator

AC24 Application Guideline

Input and Output Capacitor Requirements

The external input and output capacitors of AC24 series must be properly selected for stability and performance. Use a 1 μ F or larger input capacitor and place it close to the IC's VIN and GND pins. Any output capacitor meeting the minimum 1m Ω ESR (Equivalent Series Resistance) and effective capacitance between 1 μ F and 22 μ F requirement may be used. Place the output capacitor close to the IC's VOUT and GND pins. Increasing capacitance and decreasing ESR can improve the circuit's PSRR and line transient response.

Current Limit

The AC24 series contain the current limiter of output power transistor, which monitors and controls the transistor, limiting the output current to 700mA (typical).

The output can be shorted to ground indefinitely without damaging the part.

Dropout Voltage

The AC24 series use a PMOS pass transistor to achieve low dropout. When (VIN – VOUT) is less than the dropout voltage (V_{DROP}), the PMOS pass device is in the linear region of operation and the input-to-output resistance is the R_{DS(ON)} of the PMOS pass element. V_{DROP} scales approximately with the output current because the PMOS device behaves as a

resistor in dropout condition.

As any linear regulator, PSRR and transient response are degraded as (VIN – VOUT) approaches dropout condition.

OTP (Over Temperature Protection)

The over temperature protection function of AC24 series will turn off the P-MOSFET when the junction temperature exceeds 160°C (typ.). Once the junction temperature cools down by approximately 15°C, the regulator will automatically resume operation.

Thermal Application

For continuous operation, do not exceed the absolute maximum junction temperature. The maximum power dissipation depends on the thermal resistance of the IC package, PCB layout, rate of surrounding airflow, and difference between junction and ambient temperature. The maximum power dissipation can be calculated as below:

The max PD (Max)= (125°C – 25°C) / (200°C/W) = 0.5W for SOT-23-3 / SOT-23-5 packages.

The max PD (Max)= (125°C – 25°C) / (120°C/W) = 0.83W for SOT-89-3 package

Power dissipation (PD) is equal to the product of the output current and the voltage drop across the output pass element, as shown in the equation below:

$$PD = (VIN - VOUT) \times I_{OUT}$$

Layout Consideration

By placing input and output capacitors on the same side of the PCB as the LDO, and placing them as close as is practical to the package can achieve the best performance. The ground connections for input and output capacitors must be back to the AC24 ground pin using as wide and as short of a copper trace as is practical.



24V, 500mA Low Dropout Voltage Linear Regulator

Connections using long trace lengths, narrow trace widths, and/or connections through via must be avoided. These add parasitic inductances and resistance that results in worse performance especially during transient conditions.

AC24 Package Information

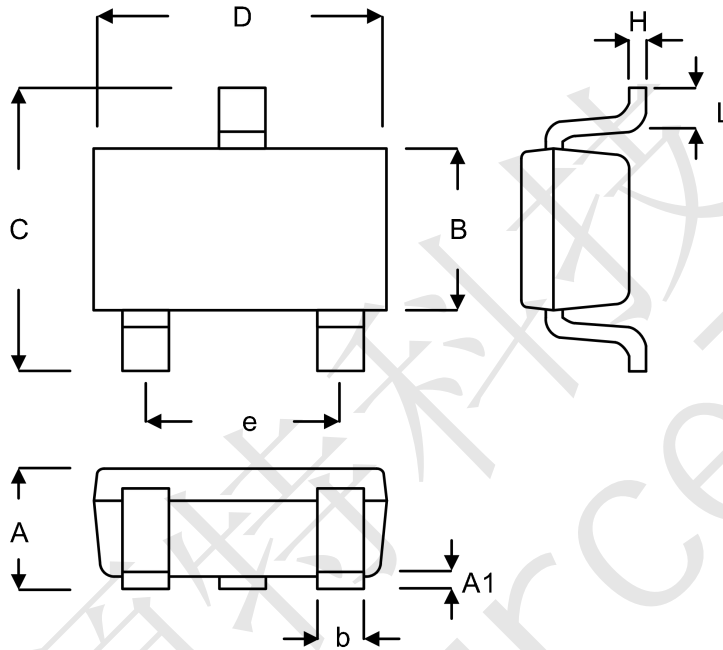

Symbol	Millimeters		Inches	
	Min.	Max.	Min.	Max.
A	0.889	1.295	0.035	0.051
A1	0.000	0.152	0.000	0.006
B	1.397	1.803	0.055	0.071
b	0.250	0.560	0.010	0.022
C	2.591	2.997	0.102	0.118
D	2.692	3.099	0.106	0.122
e	1.803	2.007	0.071	0.079
H	0.080	0.254	0.003	0.010
L	0.300	0.610	0.012	0.024

SOT-23-3L



24V, 500mA Low Dropout Voltage Linear Regulator

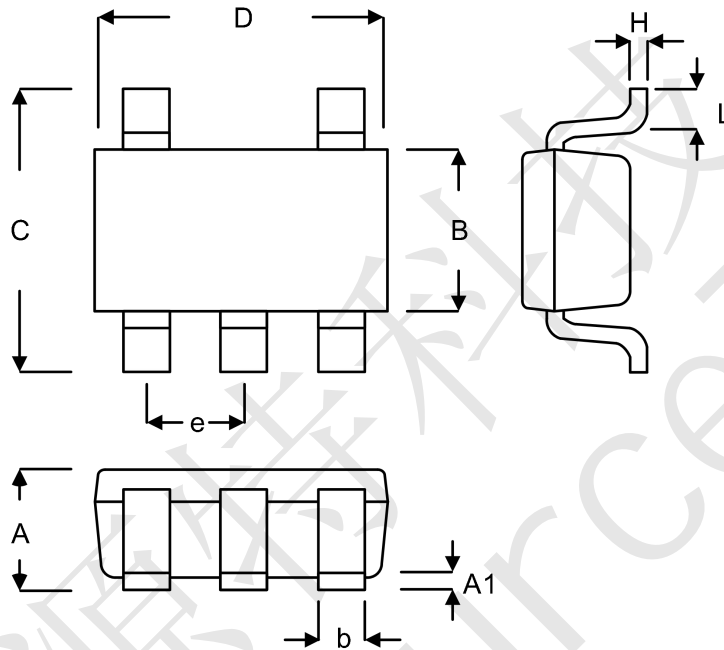

Symbol	Millimeters		Inches	
	Min.	Max.	Min.	Max.
A	0.889	1.295	0.035	0.051
A1	0.000	0.152	0.000	0.006
B	1.397	1.803	0.055	0.071
b	0.250	0.560	0.010	0.022
C	2.591	2.997	0.102	0.118
D	2.692	3.099	0.106	0.122
e	0.838	1.041	0.033	0.041
H	0.080	0.254	0.003	0.010
L	0.300	0.610	0.012	0.024

SOT-23-5L



24V, 500mA Low Dropout Voltage Linear Regulator

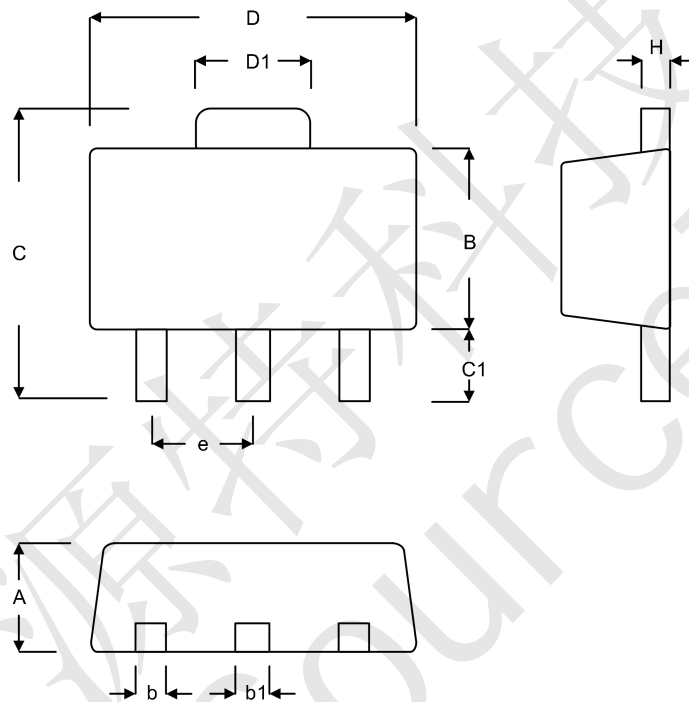

Symbol	Millimeters		Inches	
	Min.	Max.	Min.	Max.
A	1.397	1.600	0.055	0.063
b	0.356	0.483	0.014	0.019
B	2.388	2.591	0.094	0.102
b1	0.406	0.533	0.016	0.021
C	3.937	4.242	0.155	0.167
C1	0.787	1.194	0.031	0.047
D	4.394	4.597	0.173	0.181
D1	1.397	1.753	0.055	0.069
e	1.448	1.549	0.057	0.061
H	0.356	0.432	0.014	0.017