



100V 22mohm N-channel SGT MOSFET **AKG10N220KL**

AKG10N220KL Description:

This N channel SGT MOSFET has been designed to very low on-state resistance and maintain superior switching performance, especial for high efficiency power management applications.

AKG10N220KL Features:

- Low $R_{DS(ON)}$
- Ultra-low on-resistance
- RoHS compliant (Note 1)
- Halogen-free (Note 1)

AKG10N220KL Applications:

- Battery Management System
- Motor Drivers
- DC-DC Converter

AKG10N220KL Key Performance Parameters:

Parameter	Value	Unit
V_{DS}	100	V
$R_{DS(ON), max} @ V_{GS} = 10V$	22	m Ω
I_D	35	A

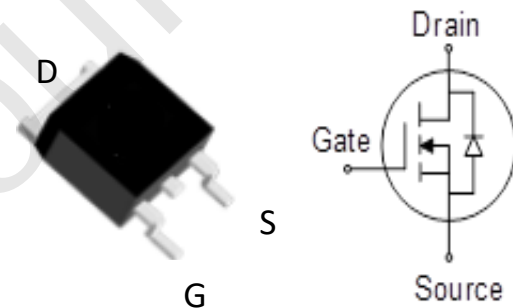

AKG10N220KL Ordering Information:

Ordering Code	Package Type	Marking Code	Form	Packing
AKG10N220KL	TO252	G10N220KL	Tape Reel	2500PCS

Notes:

1. Contact sales for detail information



100V 22mohm N-channel SGT MOSFET AKG10N220KL

AKG10N220KL Maximum Ratings ($T_A = 25^\circ\text{C}$ unless otherwise noted)

Symbol	Parameter	Value	Units
V_{DS}	Drain-Source Voltage	100	V
I_D	Drain Current - Continuous ($T_C = 25^\circ\text{C}$) (Note 1)	35	A
	Drain Current - Continuous ($T_C = 100^\circ\text{C}$)	22	A
I_{DM}	Drain Current - Pulsed (Note 2)	140	A
V_{GS}	Gate-Source Voltage	± 20	V
E_{AS}	Single Pulsed Avalanche Energy (Note 3)	38	mJ
P_D	Power Dissipation ($T_C = 25^\circ\text{C}$)	48	W
T_J, T_{STG}	Operating and Storage Temperature Range	-55 to +150	$^\circ\text{C}$

AKG10N220KL Thermal Characteristics

Symbol	Parameter	Value	Units
$R_{\theta JC}$	Thermal Resistance, Junction-to-Case, Steady-State	2.6	$^\circ\text{C}/\text{W}$
$R_{\theta JA}$	Thermal Resistance, Junction-to-Ambient, Steady State (Note 4)	56	$^\circ\text{C}/\text{W}$

Notes:

1. The max drain current rating is silicon limited
2. Repetitive Rating: Pulse width limited by maximum junction temperature
3. $L = 0.5 \text{ mH}$, $V_{DD} = 30 \text{ V}$, $I_{AS} = 12 \text{ A}$, $R_G = 25 \Omega$, Starting $T_J = 25^\circ\text{C}$
4. Mount on minimum PCB layout



100V 22mohm N-channel SGT MOSFET **AKG10N220KL**

AKG10N220KL Electrical Characteristics (T _J = 25°C unless otherwise noted)						
Symbol	Parameter	Test Conditions	Min	Typ	Max	Units
Static Characteristics						
BV _{DSS}	Drain-Source Breakdown Voltage	V _{GS} = 0 V, I _D = 250 μA	100			V
I _{DSS}	Zero Gate Voltage Drain Current	V _{DS} = 100 V, V _{GS} = 0 V,			1	μA
I _{GSS}	Gate Leakage Current	V _{GS} = ± 20 V, V _{DS} = 0 V			±100	nA
V _{GS(TH)}	Gate Threshold voltage	V _{DS} = V _{GS} , I _D = 250 μA	1	2	3	V
R _{DS(ON)}	Drain-Source on-state resistance	V _{GS} = 10 V, I _D = 20 A		18	22	mΩ
		V _{GS} = 4.5 V, I _D = 10 A		25	30	mΩ
Dynamic Characteristics						
C _{ISS}	Input Capacitance	V _{DS} = 50 V, V _{GS} = 0 V, F = 1 MHz		973		pF
C _{OSS}	Output Capacitance			238		pF
C _{RSS}	Reverse Transfer Capacitance			17.5		pF
R _G	Gate Resistance	F = 1 MHz		1.1		Ω
Switching Characteristics						
T _{D(ON)}	Turn On Delay Time	V _{DD} = 50 V, R _L = 1.7 Ω, V _{GS} = 10 V, R _G = 3 Ω		7.5		nS
T _R	Rise Time			41		nS
T _{D(OFF)}	Turn Off Delay Time			16		nS
T _F	Fall Time			8.5		nS
Q _G	Total Gate Charge	V _{DD} = 50 V, I _D = 30 A, V _{GS} = 10 V		16.7		nC
Q _{GS}	Gate-Source Charge			2.8		nC
Q _{GD}	Gate-Drain Charge			4.6		nC
Drain-Source Diode Characteristics and Maximum Ratings						
I _S	Maximum Continuous Body-Diode Forward Current			37		A
I _{SM}	Maximum Pulsed Body-Diode Forward Current ^(NOTE 1)			148		A
V _{SD}	Diode Forward Voltage	V _{GS} = 0 V, I _S = 25 A		1		V
T _{RR}	Reverse recovery time	V _{DD} = 50 V, I _D = 25 A, di/dt = 100 A/μS		42.1		nS
Q _{RR}	Reverse recovery charge			50.4		nC
I _{RRM}	Peak Reverse Recovery Current			2		A



100V 22mohm N-channel SGT MOSFET **AKG10N220KL**

AKG10N220KL Electrical Characteristics Diagrams

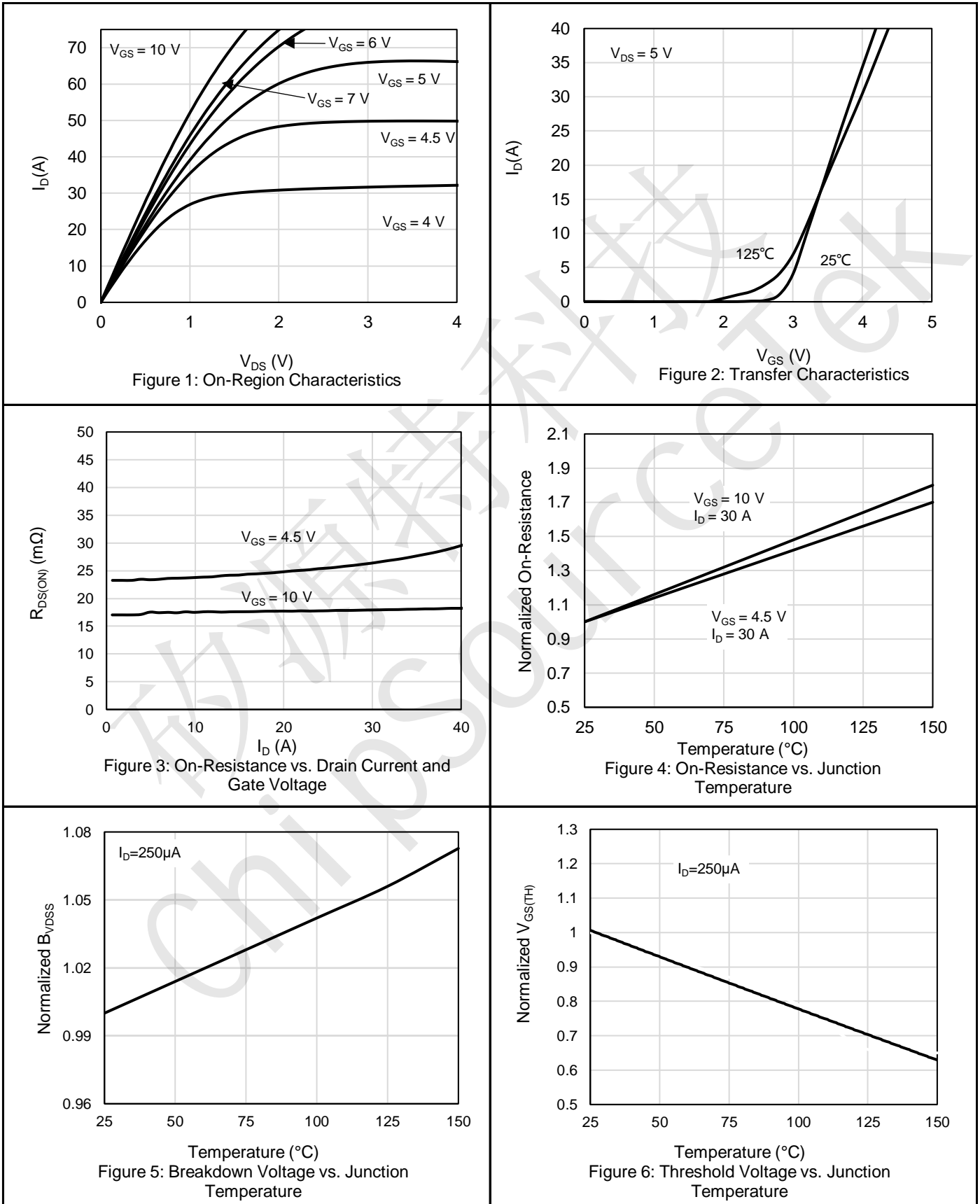



100V 22mohm N-channel SGT MOSFET **AKG10N220KL**

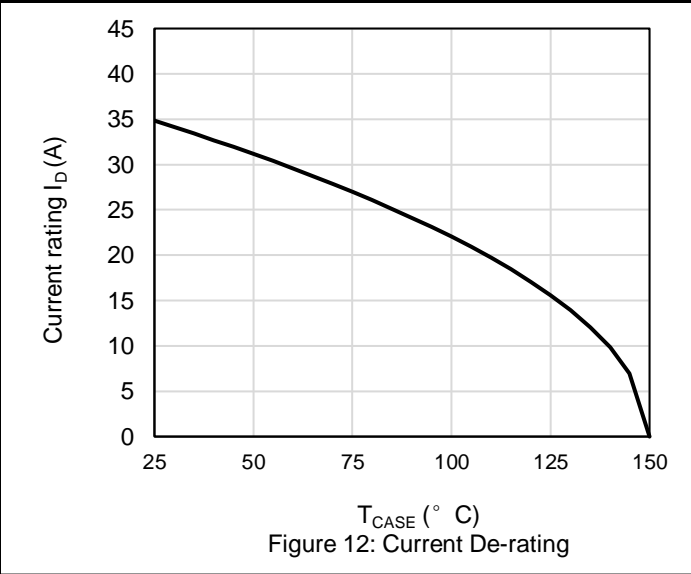
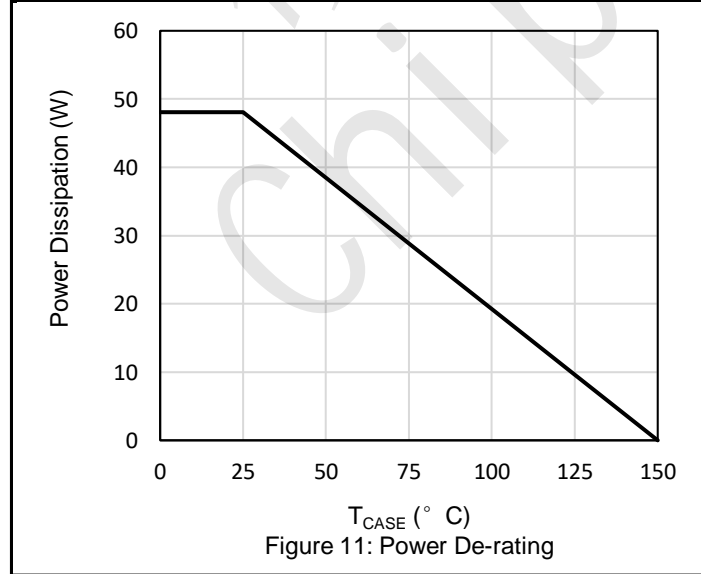
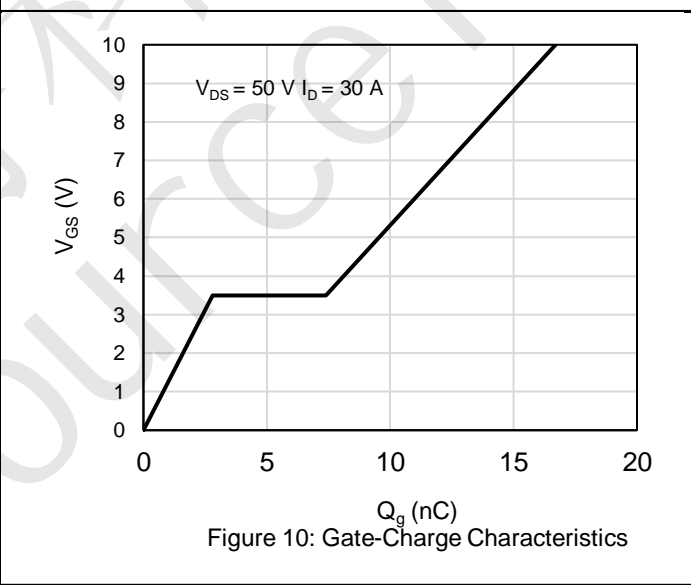
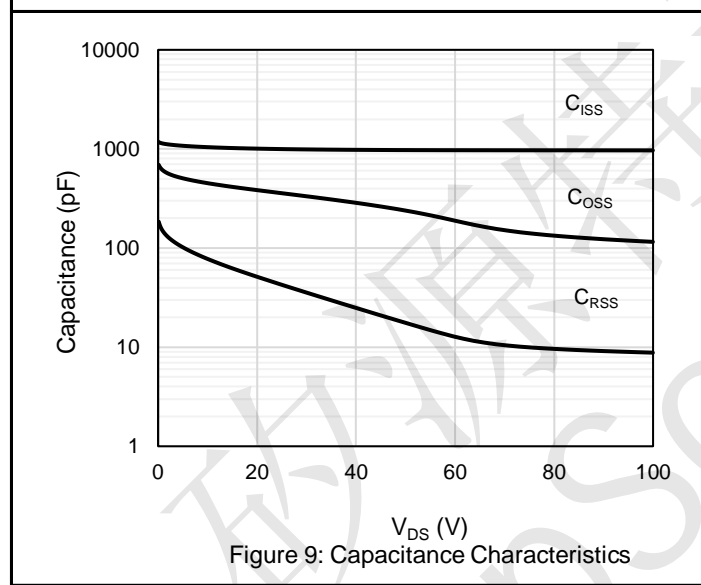
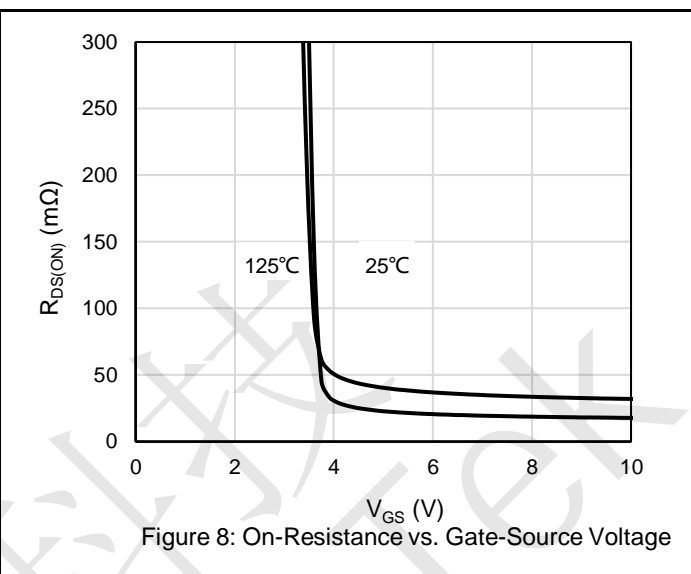
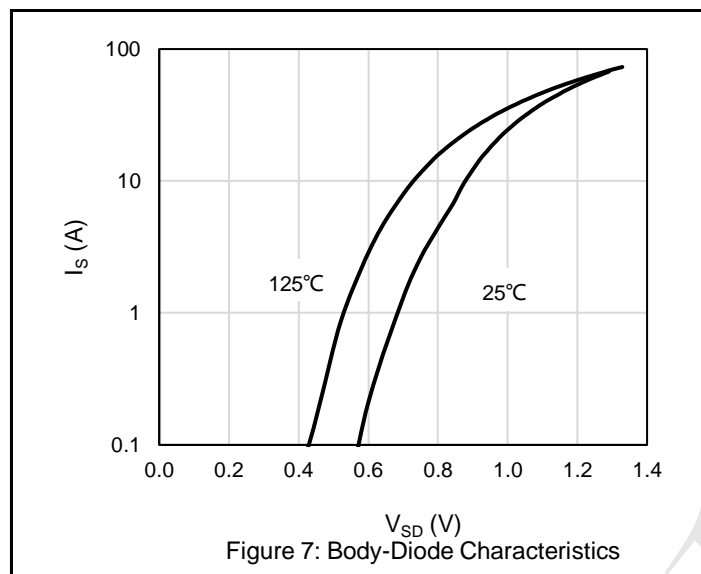



100V 22mohm N-channel SGT MOSFET **AKG10N220KL**

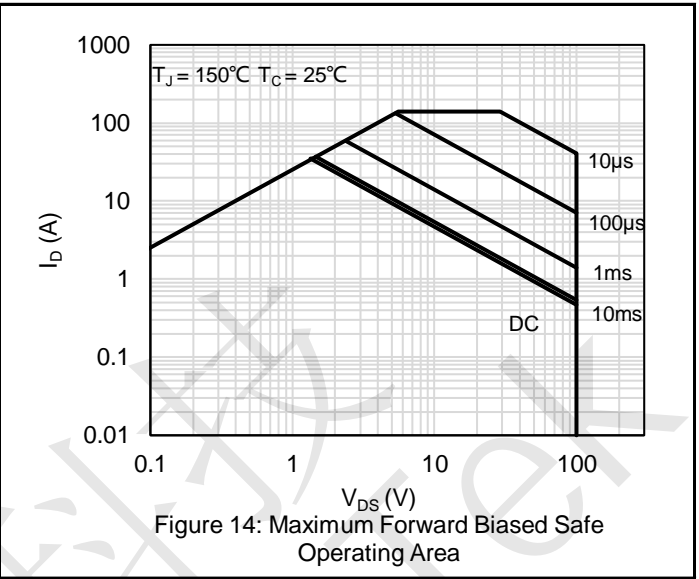
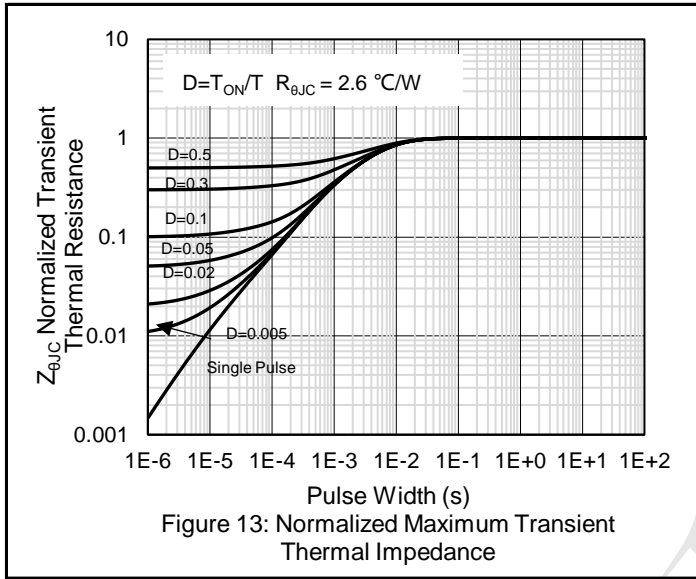



100V 22mohm N-channel SGT MOSFET AKG10N220KL

AKG10N220KL Test Circuit and Waveform

Gate Charge Test Circuit & Waveform

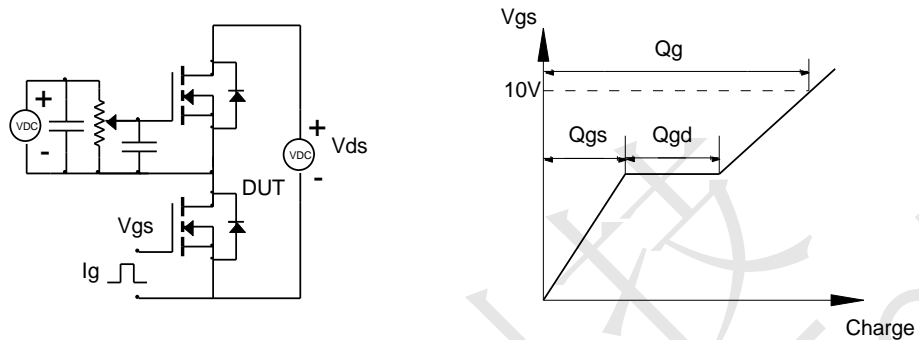

Resistive Switching Test Circuit & Waveforms

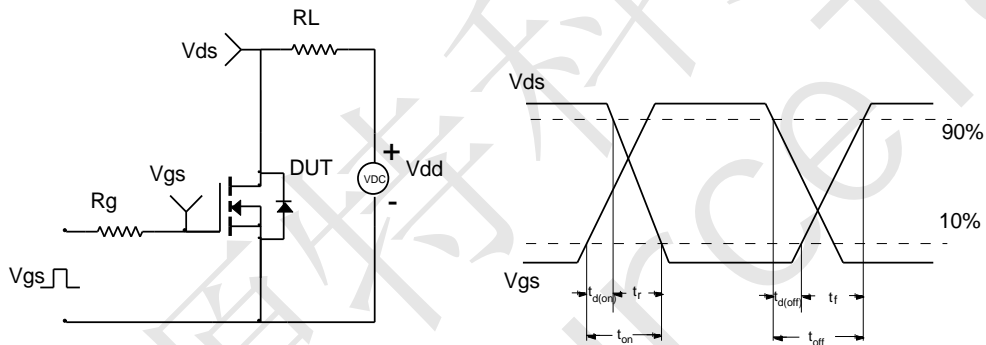

Unclamped Inductive Switching (UIS) Test Circuit & Waveforms

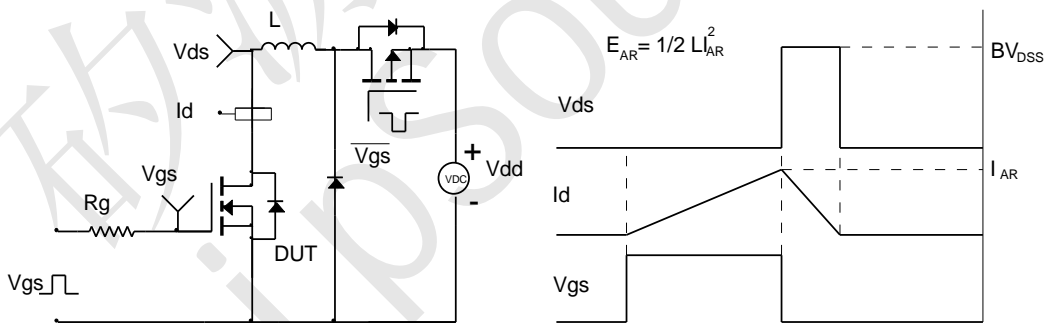

Diode Recovery Test Circuit & Waveforms

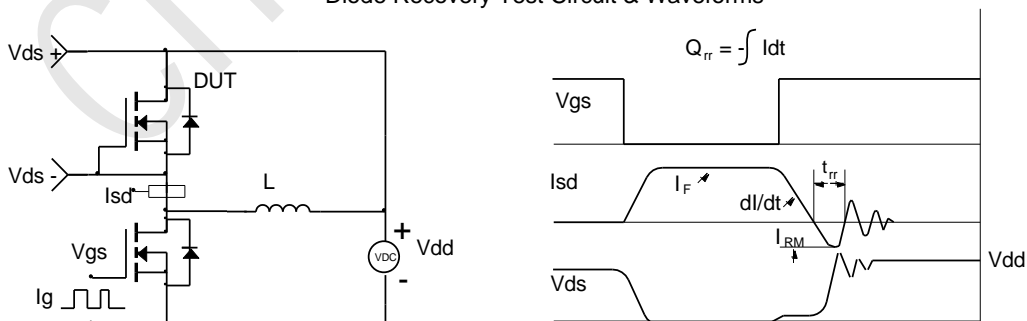



100V 22mohm N-channel SGT MOSFET **AKG10N220KL**

AKG10N220KL Package Outlines

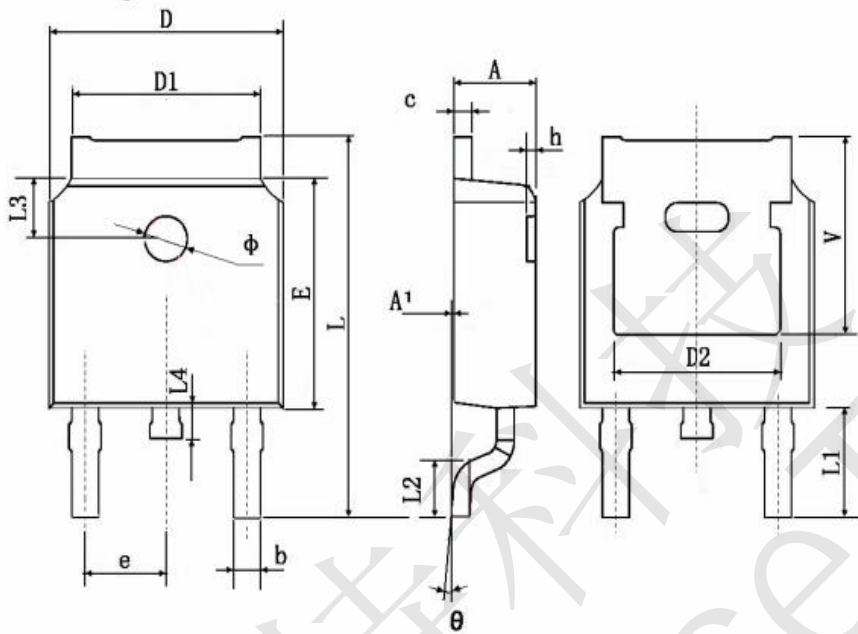

Symbol	Dimensions In Millimeters		Dimensions In Inches	
	Min.	Max.	Min.	Max.
A	2.250	2.350	0.089	0.093
A1	0.050	0.150	0.002	0.006
b	0.660	0.860	0.026	0.034
c	0.458	0.558	0.018	0.022
D	6.550	6.650	0.259	0.263
D1	5.234	5.434	0.207	0.215
D2	4.826 TYP.		0.191 TYP.	
E	6.050	6.150	0.239	0.243
e	2.236	2.336	0.088	0.092
L	9.820	10.220	0.388	0.404
L1	3.000 TYP.		0.119 TYP.	
L2	1.400	1.600	0.055	0.063
L3	1.800 TYP.		0.071 TYP.	
L4	0.700	0.900	0.028	0.036
Φ	1.150	1.250	0.045	0.049
θ	0°	3°	0°	3°
h	0.000	0.300	0.000	0.012
V	5.399 TYP		0.213 TYP	



100V 22mohm N-channel SGT MOSFET **AKG10N220KL**

AKG10N220KL Marking Information

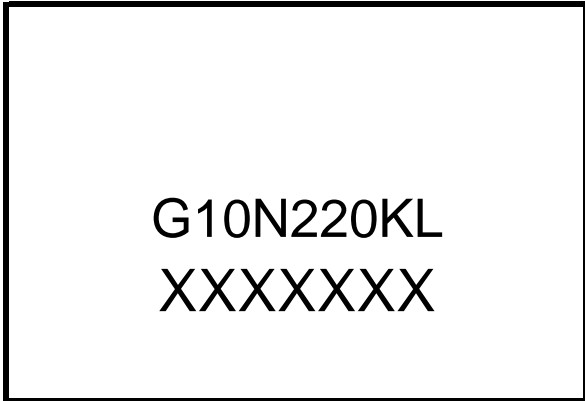

Note:
 G10N220KL = Product Name Code
 XXXXXXXX = Date code
 Contact sales for detail information

REEL DIMENSIONS

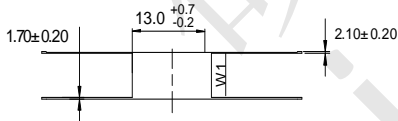
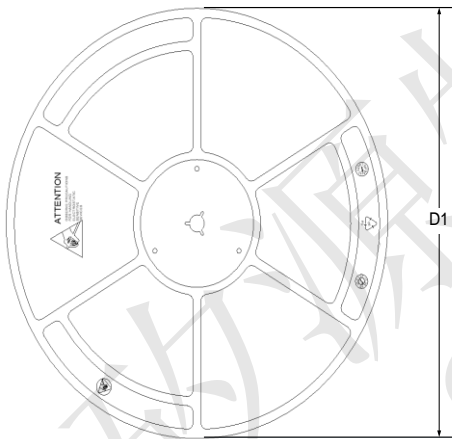

TAPE DIMENSIONS

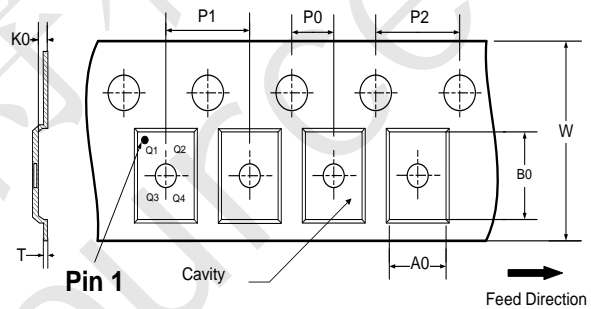

- A0: Dimension designed to accommodate the component width
- B0: Dimension designed to accommodate the component length
- K0: Dimension designed to accommodate the component thickness
- W: Overall width of the carrier tape
- P0: Pitch between successive cavity centers and sprocket hole
- P1: Pitch between successive cavity centers
- P2: Pitch between sprocket hole
- T: Tape material thickness
- D1: Reel Diameter
- W1: Reel Width

DIMENSIONS											(Unit: mm)	
Reel	D1	W1									Material	
	330	20.5									Hips	
Tape	P0	P1	P2	W	A0	B0	K0	T	Pin 1 Quadrant	Material		
	4	8	2	16	6.9	10.5	2.9	0.27	Q1	PC		

All dimensions are nominal



100V 22mohm N-channel SGT MOSFET AKG10N220KL

AKG10N220KL Revision History

Revision	Release Date	Remark
Rev.1.0	2022/7/13	Initial Release

Disclaimer

The information given in this document describes the independent performance of the product, but similar performance is not guaranteed under other working conditions, and cannot be guaranteed when installed with other products or equipment. To achieve the required performance of the product in actual scenarios, the customer should conduct a complete application test to assess the functionality of the product.

Assumes no responsibility for equipment failures result from using products at values that exceed the ratings, operating conditions, or other parameters listed in the product specifications.

The product described in this specification is not applicable for aerospace or other applications which requires high reliability. Customers using or selling these products for use in medical, life-saving, or life-sustaining applications do so at their own risk and agree to fully indemnify.

Due to product or technical improvements, the information described or contained herein may be changed without prior notice.