



## AKT3080K 30V N-channel enhancement mode MOSFET

### AKT3080K Features

- Extremely Low RDS(on):  
Typ.RDS(on) = 4.0 mΩ @V<sub>GS</sub>=10 V, I<sub>d</sub>=30 A
- Good stability and uniformity
- 100% avalanche tested
- Excellent package for good heat dissipation

### AKT3080K General Description

The AKT3080K uses advanced trench technology to provide excellent RDS(ON), low gate charge This device is suitable for use in Load Switch,PWM Application, Power Management and general purpose applications.

TO-252-2L Package

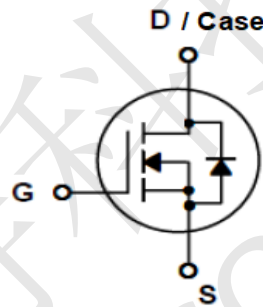
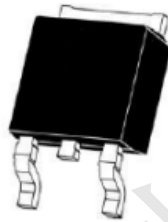

Symbol	Parameter	Value	Units
V <sub>DS</sub>	Drain-Source Voltage	30	V
I <sub>D</sub>	Drain Current - Continuous (TC= 25°C) - Continuous (TC= 100°C)	80	A
		52*	A
I <sub>DM</sub>	Drain Current - Pulsed (Note 1)	320*	A
V <sub>GS</sub>	Gate-Source Voltage	± 20	V
E <sub>AS</sub>	Single Pulsed Avalanche Energy (Note 2)	131	mJ
P <sub>D</sub>	Power Dissipation (TC = 25°C)	128	W
T <sub>J</sub> , T <sub>stg</sub>	Operating and Storage Temperature Range	-55 to +175	°C

\* Drain current limited by maximum junction temperature

### Thermal Characteristics

Symbol	Parameter	Value	Units
R <sub>θJC</sub>	Thermal Resistance, Junction-to-Case	0.973	°C/W
R <sub>θJA</sub>	Thermal Resistance, Junction-to-Ambient	47.13	°C/W



AKT3080K Electrical Characteristics TC = 25°C unless otherwise noted

Symbol	Parameter	Test Conditions	Min	Typ	Max	Units
<b>Off Characteristics</b>						
$BV_{DSS}$	Drain-Source Breakdown Voltage	$V_{GS} = 0\text{ V}, I_D = 250\ \mu\text{A}$	30			V
$I_{DSS}$	Zero Gate Voltage Drain Current	$V_{DS} = 29.5\text{ V}, V_{GS} = 0\text{ V}$			1	$\mu\text{A}$
$I_{GSSF}$	Gate Leakage Current, Forward	$V_{GS} = 20\text{ V}, V_{DS} = 0\text{ V}$			100	nA
$I_{GSSR}$	Gate Leakage Current, Reverse	$V_{GS} = -20\text{ V}, V_{DS} = 0\text{ V}$			-100	nA
<b>On Characteristics</b>						
$V_{GS(TH)}$	Gate Threshold voltage	$V_{DS} = V_{GS}, I_D = 250\ \mu\text{A}$	1	1.5	2.2	V
$R_{DS(On)}$	Drain-Source on-state resistance	$V_{GS} = 10\text{ V}, I_D = 30\text{ A}$		4.0	5.5	m $\Omega$
		$V_{GS} = 4.5\text{ V}, I_D = 20\text{ A}$		7.0	9.8	m $\Omega$
<b>Dynamic Characteristics</b>						
$C_{iss}$	Input capacitance	$V_{DS}=15\text{V}, V_{GS}=0\text{V},$ $F=1.0\text{Mhz}$		1650		pF
$C_{oss}$	Output capacitance			245		pF
$C_{riss}$	Reverse transfer capacitance			225		pF
<b>Switching Characteristics</b>						
$t_{d(on)}$	Turn On Delay Time	$V_{DD}=15\text{V}, I_D=30\text{A},$ $V_{GS}=10\text{V}, R_G=30\Omega$ (Note 3, 4)		5		ns
$t_r$	Rising Time			26		ns
$t_{d(off)}$	Turn Off Delay Time			18		ns
$t_f$	Fall Time			17		ns
$Q_g$	Total Gate Charge			34		nC
$Q_{gs}$	Gate-Source Charge			4.0		nC
$Q_{gd}$	Gate-Drain Charge		7.1		nC	
<b>Drain-Source Diode Characteristics and Maximum Ratings</b>						
$I_S$	Maximum Continuous Drain-Source Diode Forward Current				80	A
$I_{SM}$	Maximum Pulsed Drain-Source Diode Forward Current				320	A
$V_{SD}$	Diode Forward Voltage	$V_{GS} = 0\text{ V}, I_S = 30\text{ A}$			1.2	V

**Notes:**

1. Repetitive Rating : Pulse width limited by maximum junction temperature
2.  $L = 0.5\text{ mH}, V_{DD} = 15\text{ V}, R_G = 25\ \Omega, V_{GS} = 10\text{ V},$  Starting  $T_j = 25^\circ\text{C}$
3.  $I_{SD} \leq 30\text{ A}, di/dt = 100\text{A}/\mu\text{s}, V_{DD} \leq BV_{DSS},$  Starting  $T_j = 25^\circ\text{C}$
4. Pulse Test : Pulse width  $\leq 300\mu\text{s},$  Duty cycle  $\leq 2\%$
5. Essentially independent of operating temperature



## Test Circuit & Waveform

### Gate Charge Test Circuit & Waveform

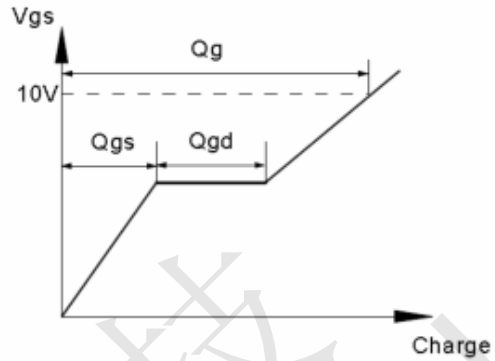
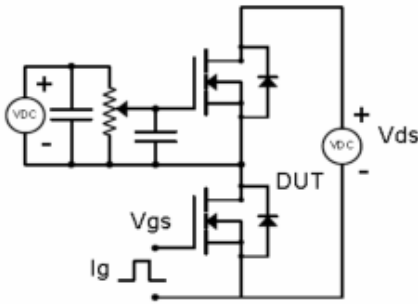

### Resistive Switching Test Circuit & Waveforms

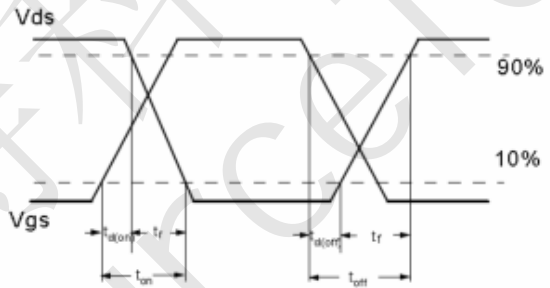
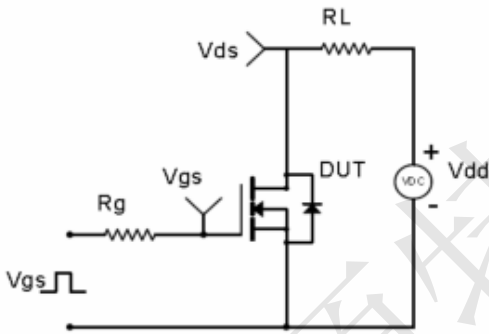

### Unclamped Inductive Switching (UIS) Test Circuit & Waveforms

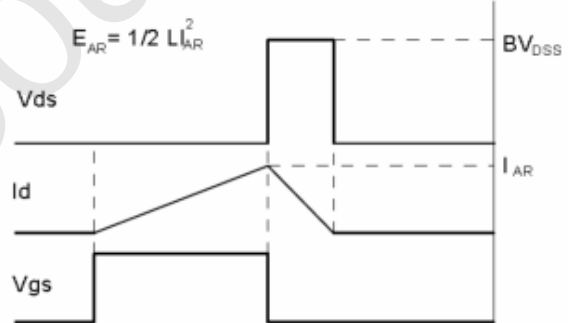
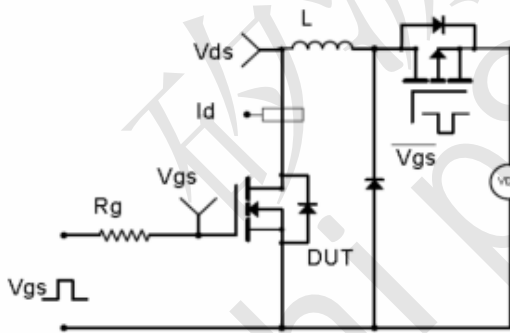

### Diode Recovery Test Circuit & Waveforms

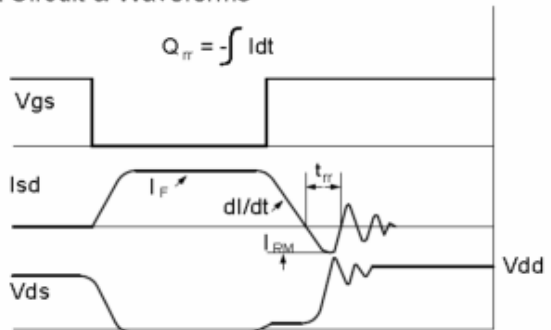
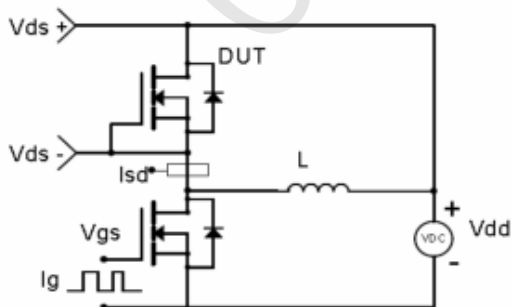



### AKT3080K Typical Performance Characteristics

Fig.1 Power Dissipation Derating Curve

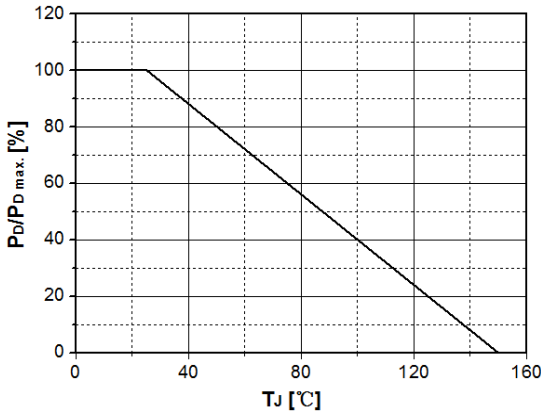

Fig.2 Avalanche Energy Derating Curve vs. Junction Temperature

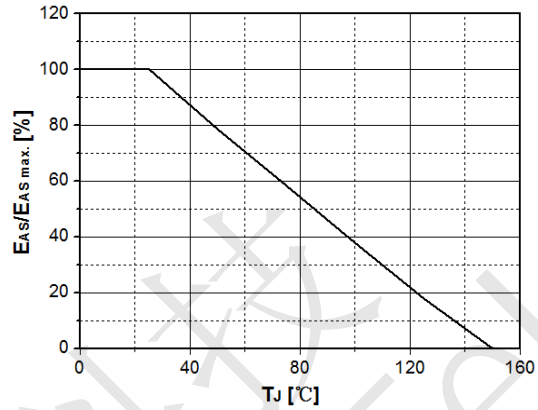

Fig.3 Typical Output Characteristics

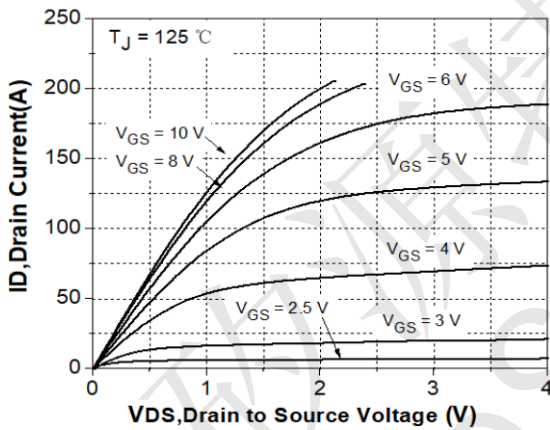

Fig.4 Transconductance vs. Drain Current

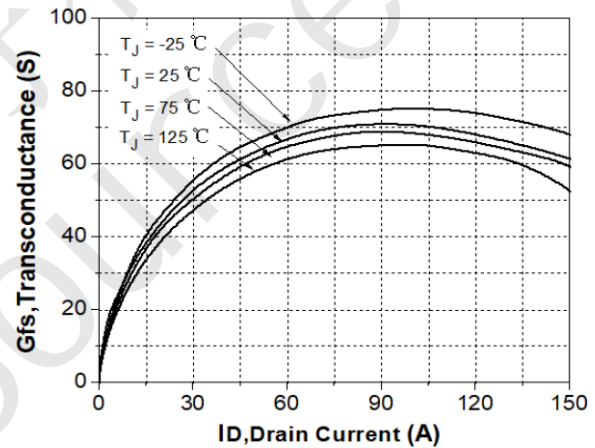

Fig.5 Typical Transfer Characteristics

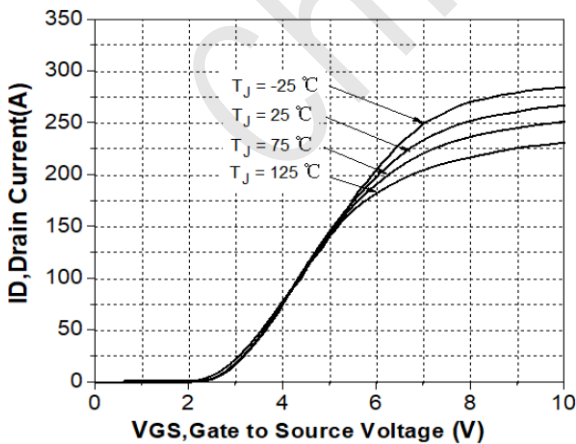

Fig.6 State Resistance vs. Drain Current @-25°C

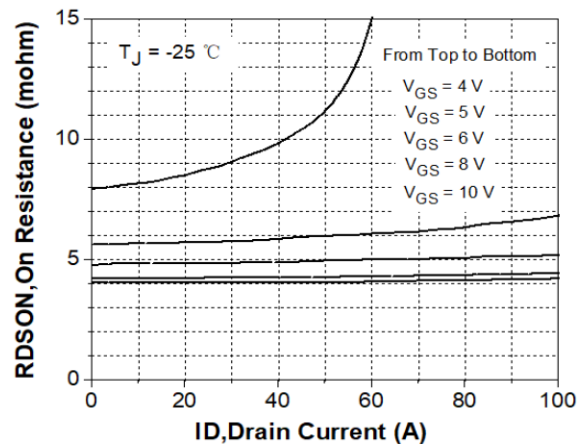



Fig. 7 State Resistance vs. Drain Current @25°C

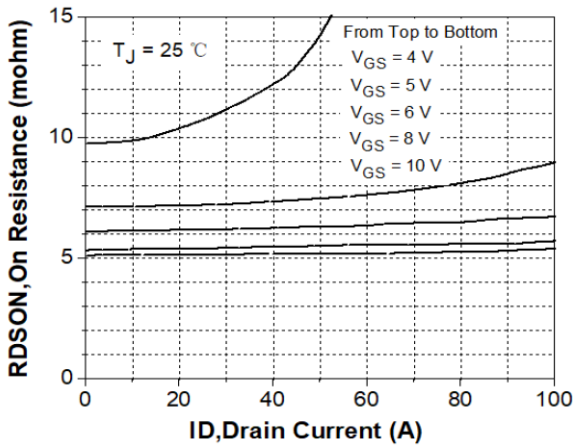

Fig. 8 State Resistance vs. Drain Current @125°C

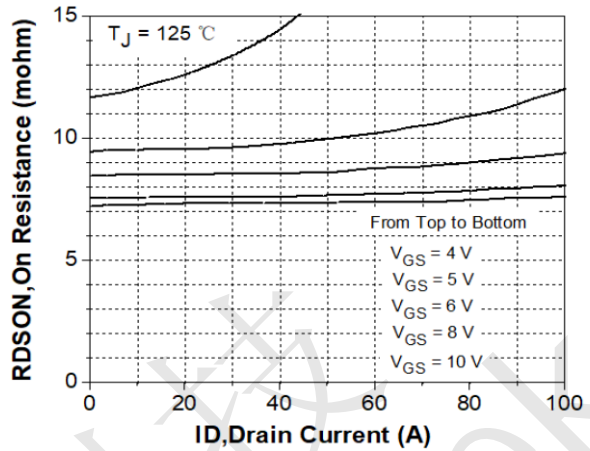

Fig.9 Typical Capacitance vs. Drain Source Voltage

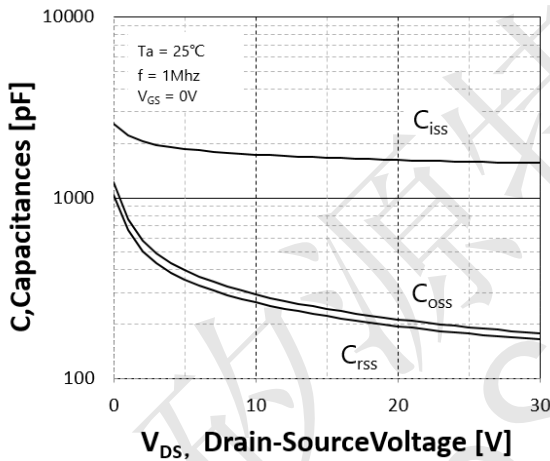

Fig.10 Dynamic Input Characteristics

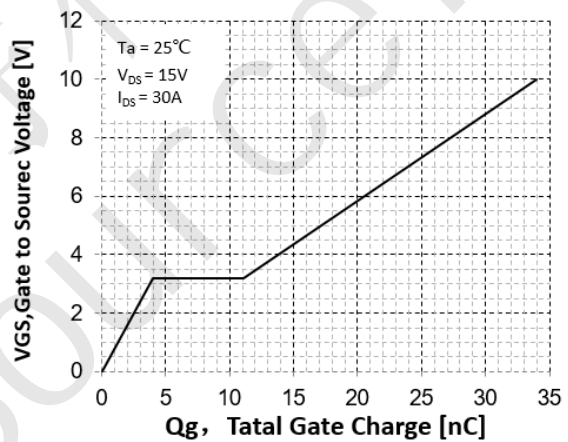

Fig.11 Breakdown Voltage vs. Junction Temperature

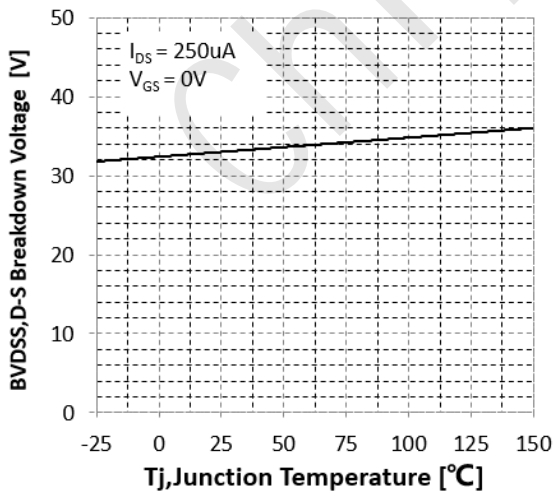

Fig. 12 Gate Threshold Voltage vs. Junction Temperature

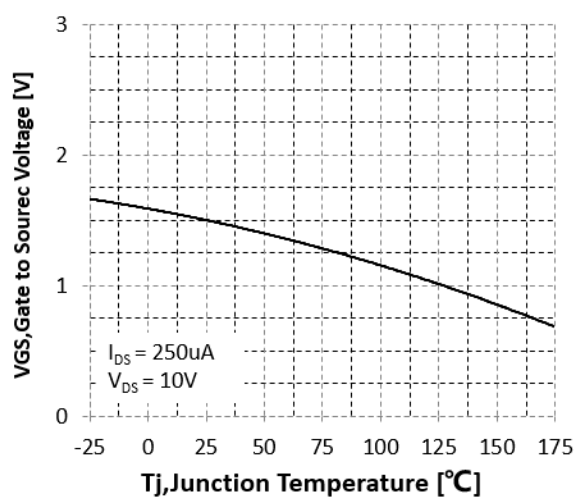



Fig.13 On-Resistance Variation vs. Junction Temperature

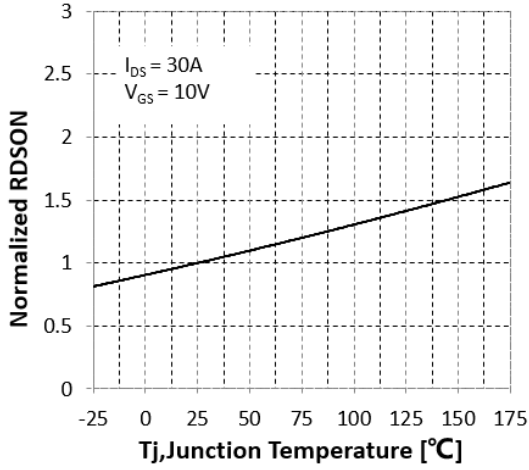

Fig.14 Maximum Drain Current vs. Case Temperature

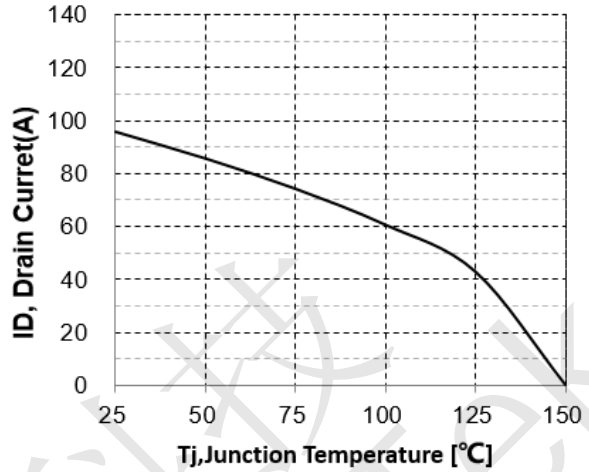

Fig.15 Body Diode Forward Voltage Vs Reverse Drain Current

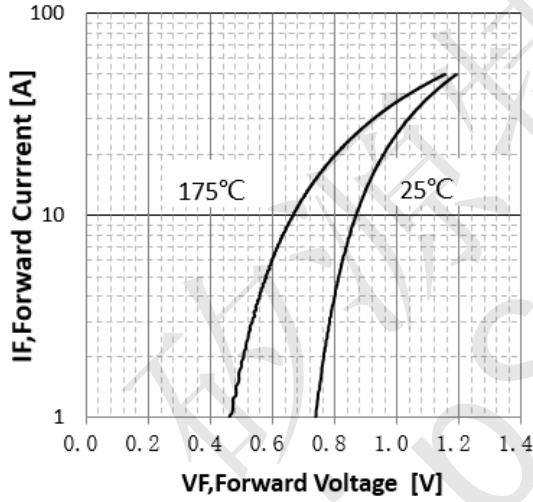



Fig.16 Safe Operating Area

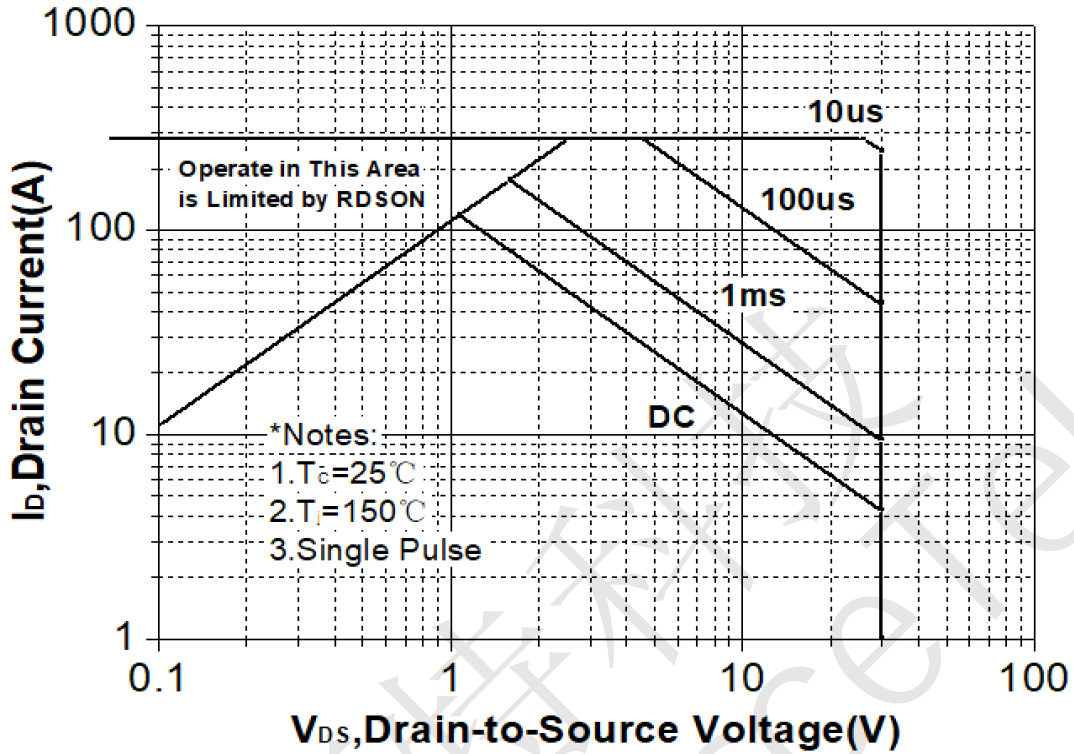
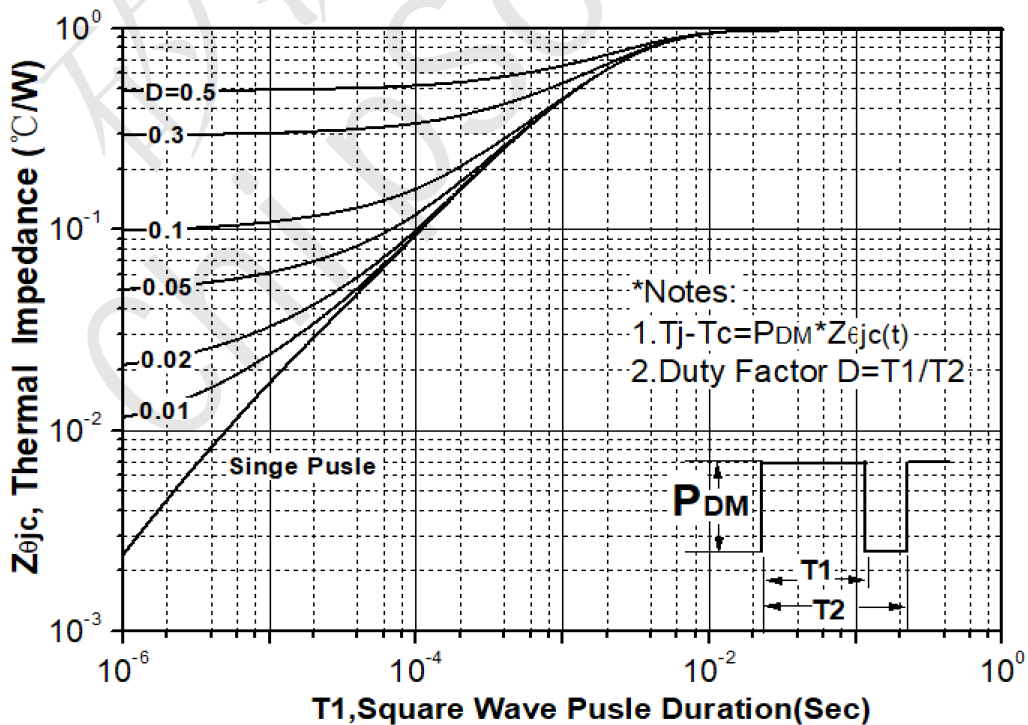
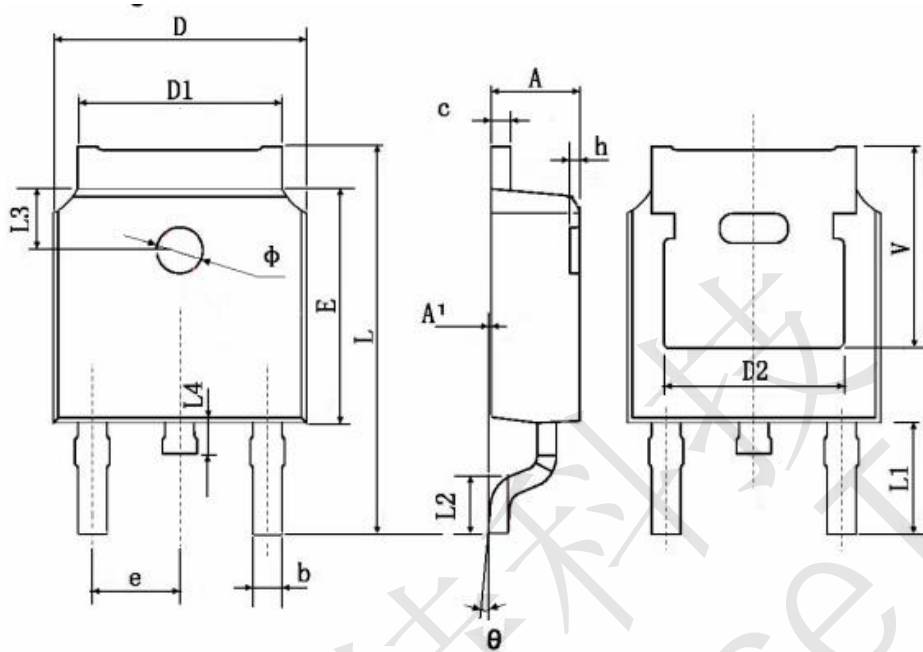

Fig. 17 Transient Thermal Response Curve





## AKT3080 Package Dimensions : TO-252-2L PACKAGE



Symbol	Dimensions In Millimeters		Dimensions In Inches	
	Min.	Max.	Min.	Max.
A	2.250	2.350	0.089	0.093
A1	0.050	0.150	0.002	0.006
b	0.660	0.860	0.026	0.034
c	0.458	0.558	0.018	0.022
D	6.550	6.650	0.259	0.263
D1	5.234	5.434	0.207	0.215
D2	4.826 TYP.		0.191 TYP.	
E	6.050	6.150	0.239	0.243
e	2.236	2.336	0.088	0.092
L	9.820	10.220	0.388	0.404
L1	3.000 TYP.		0.119 TYP.	
L2	1.400	1.600	0.055	0.063
L3	1.800 TYP.		0.071 TYP.	
L4	0.700	0.900	0.028	0.036
Φ	1.150	1.250	0.045	0.049
θ	0°	3°	0°	3°
h	0.000	0.300	0.000	0.012
V	5.399 TYP		0.213 TYP	