



TX2304 Synchronous Step-Up DC-DC Converter with PFM Control

TX2304 Features

- External parts: Coil, capacitor
- Output voltage: Settable to between 2.1V to 5.0V in 0.1V steps
- Maximum Oscillation frequency :300KHz
- Accuracy of $\pm 2\%$
- High efficiency :95%
- Package: SOT23, SOT23-3, SOT23-5, SOT89 and DFN1*1

TX2304 Applications

- Digital cameras
- Electronic notebooks and PDAS
- Portable CD/MD players
- Cameras, video equipment
- Communications equipment
- Power supply for microcomputers

TX2304 General Description

The TX2304 Series is a Synchronous step-up DC/DC Converter with PFM Control. With the TX2304 Series, a step-up switching DC/DC converter can be configured by using

an external coil, capacitor. The built-in MOSFET is turned off by a protection circuit when the voltage at the LX pin exceeds the limit to prevent it from being damaged.

TX2304 Block Diagram

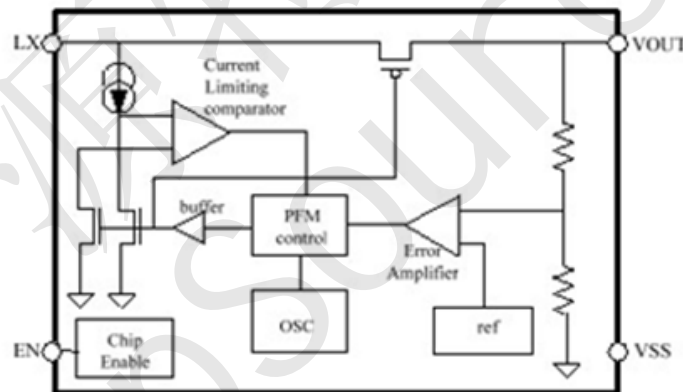

TX2304 Order Information

TX2304-①②③④

Designator	Symbol	Description
① ②	Integer	Output Voltage (2.1~5.0) e.g:3.0V=②: 3; ③: 0
③	N	Package: SOT23
	M	Package: SOT23-3
	M5	Package: SOT23-5
	P	Package: SOT89
	FC	Package: DFN1*1
④	G	Halogen Free



TX2304 Pin Assignment

SOT23 and SOT23-3 (Top View)

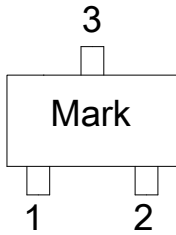

Table1 TX2304-XXNG/MG series (SOT23/SOT23-3 PKG)

PIN NO.	PIN NAME	FUNCTION
1	GND	GND pin
2	LX	External inductor connection pin
3	VOUT	Output voltage pin

SOT23-5 (Top View)

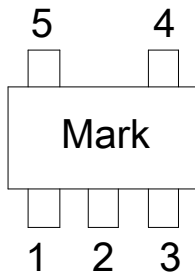

Table2 TX2304-XXM5G series (SOT23-5 PKG)

PIN NO.	PIN NAME	FUNCTION
1	EN	Shutdown pin
2	VOUT	Output voltage pin
3	NC	(N.C.)
4	GND	GND pin
5	LX	External inductor connection pin

SOT89 (Top View)

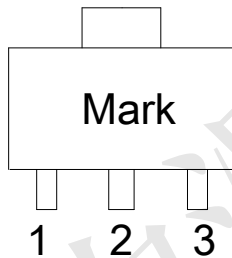

Table3 TX2304-XXPG series (SOT89 PKG)

PIN NO.	PIN NAME	FUNCTION
1	GND	GND pin
2	VOUT	Output voltage pin
3	LX	External inductor connection pin

DFN1*1-4L (Top View)

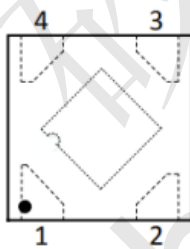

Table4 TX2304-XXFCG series (DFN1*1PKG)

PIN NO.	PIN NAME	FUNCTION
1	LX	External inductor connection pin
2	GND	GND pin
3	CE	Enable pin
4	VOUT	Output voltage pin



TX2304 Marking Rule

①② product code: B1

③ output voltage code:

Symbol	Voltage(V)	Symbol	Voltage(V)	Symbol	Voltage(V)	Symbol	Voltage(V)
a	0.9	A	3.5	n	2.2	N	4.8
b	1.0	B	3.6	o	2.3	O	4.9
c	1.1	C	3.7	P	2.4	P	5.0
d	1.2	D	3.8	q	2.5	Q	5.1
e	1.3	E	3.9	r	2.6	R	5.2
f	1.4	F	4.0	s	2.7	S	5.3
g	1.5	G	4.1	t	2.8	T	5.4
h	1.6	H	4.2	u	2.9	U	5.5
i	1.7	I	4.3	v	3.0	V	5.6
j	1.8	J	4.4	w	3.1	W	5.7
k	1.9	K	4.5	x	3.2	X	5.8
l	2.0	L	4.6	y	3.3	Y	5.9
m	2.1	M	4.7	z	3.4	Z	6.0

④⑤:

The last two of them are based on the time of this product which is the first time into production, the fourth is the year of this product first time into production, such as expressed in "5" in 2015, in "6" in 2016 and the fifth is the month of this product first time into production, it can be in 1 ~ 9, which is expressed in "0" in October, in November with an "A", in December with "B"; . For example: B1y58 represents TX2304-33NG product is first put into production in August in 2015.



TX2304 Absolute Maximum Ratings

(Unless otherwise specified, Ta=25°C)

PARAMETER		SYMBOL	RATINGS	UNITS
VOUT Pin Voltage		V _{OUT}	0~ 8	V
EN Pin Voltage		EN	0~V _{IN}	V
VIN Pin Voltage		V _{IN}	0~V _{OUT}	V
LX Pin Voltage		V _{LX}	V _{SS} -0.3~V _{SS} +8	V
LX Pin Current		I _{LX}	600	mA
Power Dissipation	SOT23	PD	250	mW
	SOT23-3/SOT23-5		250	mW
	SOT89-3		500	mW
	DFN1*1-4L		500	mW
Operating Temperature		T _{OPR}	-40~+85	°C
Storage Temperature		T _{STG}	-40~+125	°C
Soldering Temperature & Time		T _{SOLDER}	260°C, 10s	

Note: These are stress ratings only. Stresses exceeding the range specified under “Absolute Maximum Ratings” may cause substantial damage to the device. Functional operation of this device at other conditions beyond those listed in the specification is not implied and prolonged exposure to extreme conditions may affect device reliability.

TX2304 Electrical Characteristics

(Unless otherwise specified, Ta = 25°C)

PARAMETER	SYMBOL	MIN	TYP	MAX	UNITS	CONDITION
Output Voltage	V _{OUT}	V _{OUT(S)} X0.98	V _{OUT}	V _{OUT(S)} X1.02	V	-
Input Voltage	V _{IN}	-	-	V _{OUT}	V	-
Operation Start Voltage	V _{ST1}	-	-	0.8	V	I _{OUT} =1mA
Input Current At No Load	I _{SS1}	-	8	25	uA	V _{IN} =2.0V, V _{OUT} =3.3V
Current Consumption 2	I _{SS2}	-	5	--	uA	V _{OUT} =V _{OUT(S)} +0.5V
Current Consumption During Shutdown	I _{SSS}	-	-	1.0	uA	V _{EN} =0V
Maximum Oscillation Frequency	f _{osc}		300		KHz	V _{OUT} =0.95xV _{OUT(S)} , measure Waveform at LX pin
Duty Ratio	Duty	70	78	85	%	V _{OUT} =0.95xV _{OUT(S)}
Efficiency	EFFI		85		%	
Shutdown Pin Input Voltage	V _{SH}	0.75	-	-	V	V _{OUT} =0.95xV _{OUT(S)} , judge Oscillation at LX pin
	V _{SL}	-	-	0.3	V	V _{OUT} =0.95xV _{OUT(S)} , judge stop at LX pin
Shutdown Pin input Current	I _{SH}	-0.1	-	0.1	uA	V _{EN} =6V
	I _{SL}	-0.1	-	0.1	uA	V _{EN} =0V

Remark: V_{OUT(S)} specified above is the set output voltage value and V_{OUT} is the typical value of the actual output voltage



TX2304 Application Circuits

1) TX2304 without CE

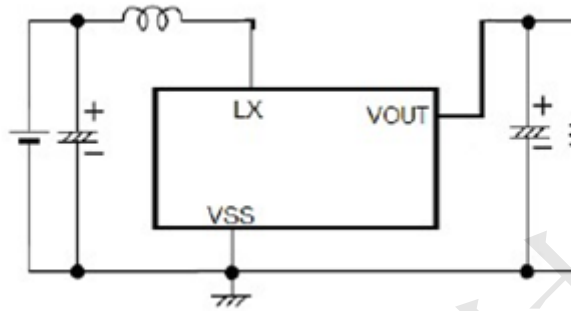

2) TX2304 with CE

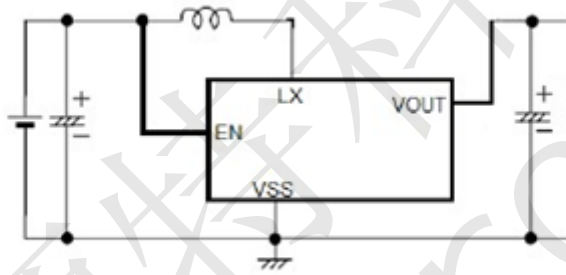

Note: External Component Recommendation:

- 1) L=47uH(Sumida)
- 2) C=100uF/16V(Tantalum)



TX2304 Package Information

3-pin SOT23 Outline Dimensions

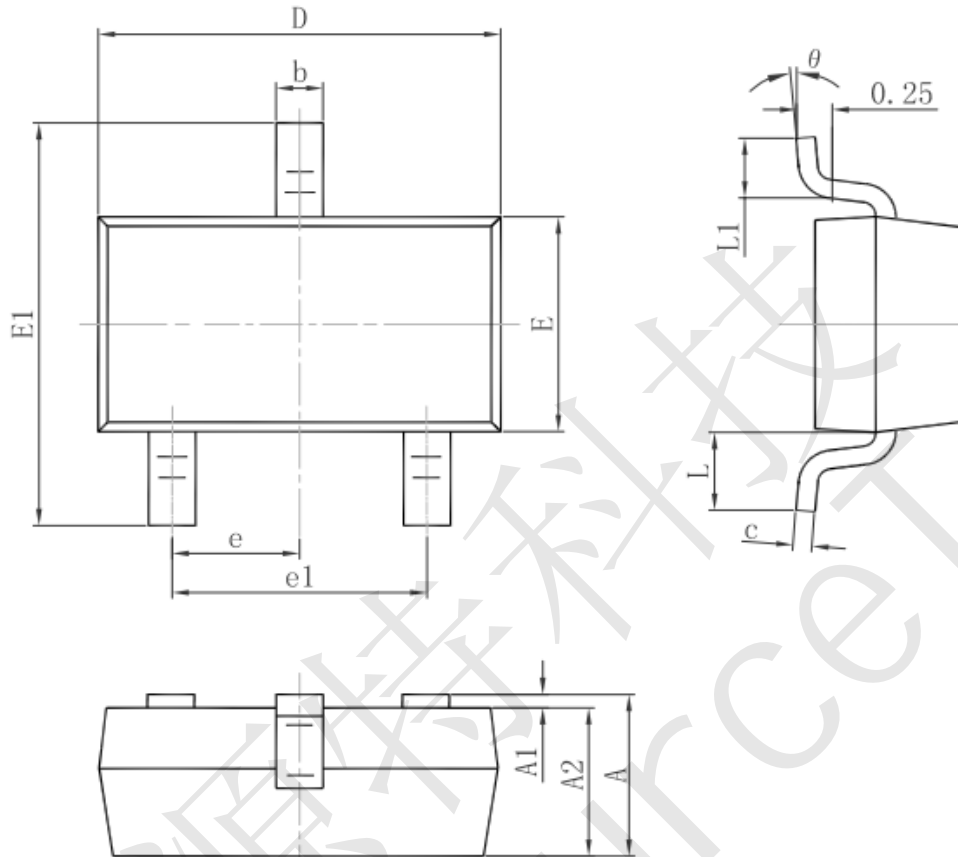

Symbol	Dimensions In Millimeters		Dimensions In Inches	
	Min.	Max.	Min.	Max.
A	0.900	1.150	0.035	0.045
A1	0.000	0.100	0.000	0.004
A2	0.900	1.050	0.035	0.041
b	0.300	0.500	0.012	0.020
c	0.080	0.150	0.003	0.006
D	2.800	3.000	0.110	0.118
E	1.200	1.400	0.047	0.055
E1	2.250	2.550	0.089	0.100
e	0.950 TYP.		0.037 TYP.	
e1	1.800	2.000	0.071	0.079
L	0.550 REF.		0.022 REF.	
L1	0.300	0.500	0.012	0.020
θ	0°	8°	0°	8°



3-pin SOT23-3 Outline Dimensions

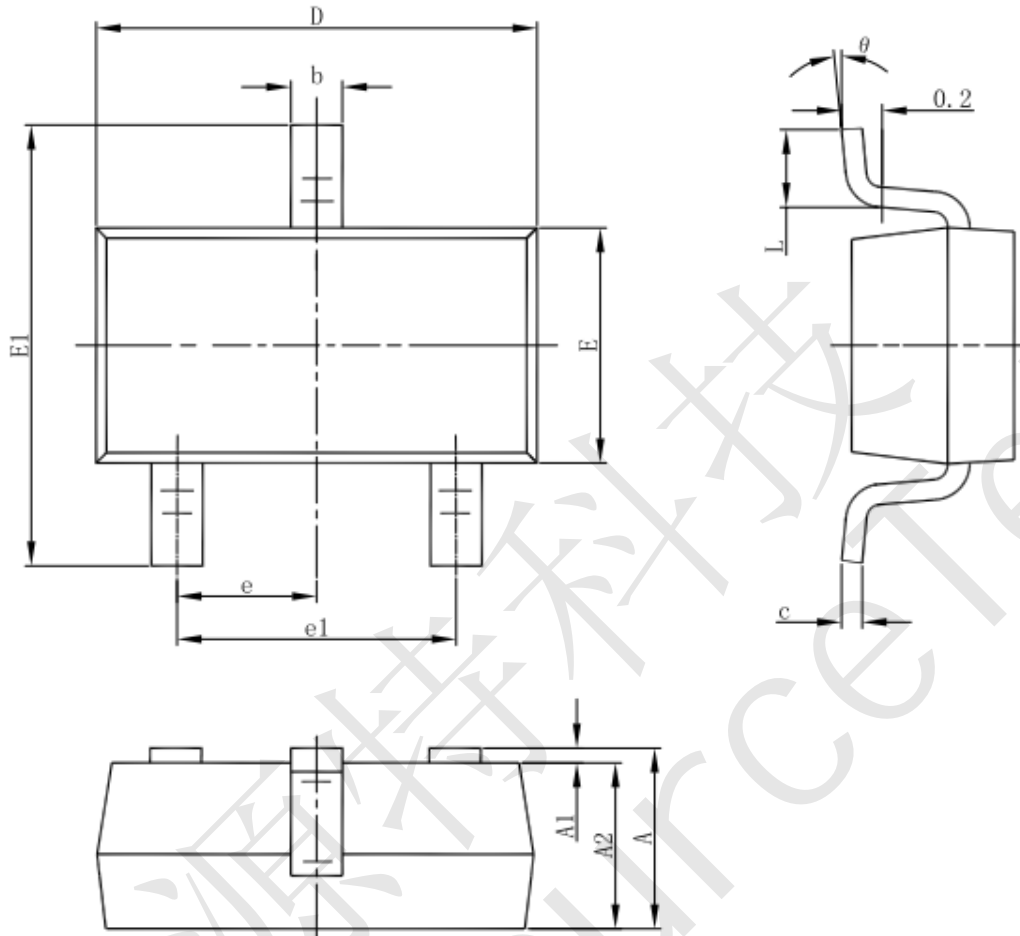

Symbol	Dimensions In Millimeters		Dimensions In Inches	
	Min	Max	Min	Max
A	1.050	1.250	0.041	0.049
A1	0.000	0.100	0.000	0.004
A2	1.050	1.150	0.041	0.045
b	0.300	0.500	0.012	0.020
c	0.100	0.200	0.004	0.008
D	2.820	3.020	0.111	0.119
E	1.500	1.700	0.059	0.067
E1	2.650	2.950	0.104	0.116
e	0.950(BSC)		0.037(BSC)	
e1	1.800	2.000	0.071	0.079
L	0.300	0.600	0.012	0.024
θ	0°	8°	0°	8°



5-pin SOT23-5L Outline Dimensions

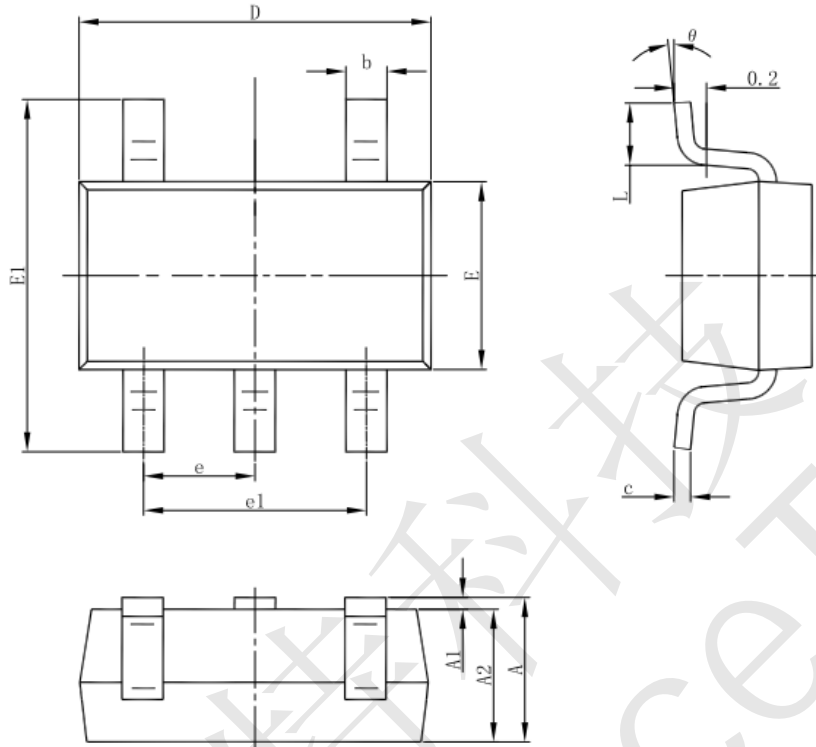

Symbol	Dimensions In Millimeters		Dimensions In Inches	
	Min	Max	Min	Max
A	1.050	1.250	0.041	0.049
A1	0.000	0.100	0.000	0.004
A2	1.050	1.150	0.041	0.045
b	0.300	0.500	0.012	0.020
c	0.100	0.200	0.004	0.008
D	2.820	3.020	0.111	0.119
E	1.500	1.700	0.059	0.067
E1	2.650	2.950	0.104	0.116
e	0.950(BSC)		0.037(BSC)	
e1	1.800	2.000	0.071	0.079
L	0.300	0.600	0.012	0.024
θ	0°	8°	0°	8°



3-pin SOT89-3 Outline Dimensions

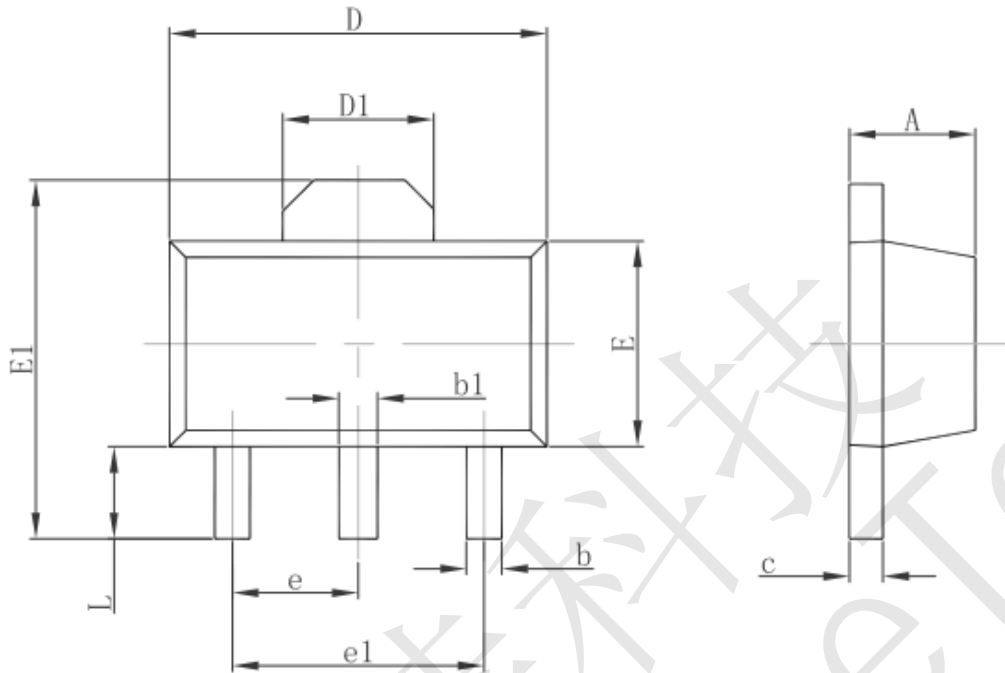

Symbol	Dimensions In Millimeters		Dimensions In Inches	
	Min.	Max.	Min.	Max.
A	1.400	1.600	0.055	0.063
b	0.320	0.520	0.013	0.020
b1	0.400	0.580	0.016	0.023
c	0.350	0.440	0.014	0.017
D	4.400	4.600	0.173	0.181
D1	1.550 REF.		0.061 REF.	
E	2.300	2.600	0.091	0.102
E1	3.940	4.250	0.155	0.167
e	1.500 TYP.		0.060 TYP.	
e1	3.000 TYP.		0.118 TYP.	
L	0.900	1.200	0.035	0.047



DFN1*1-4L Outline Dimensions

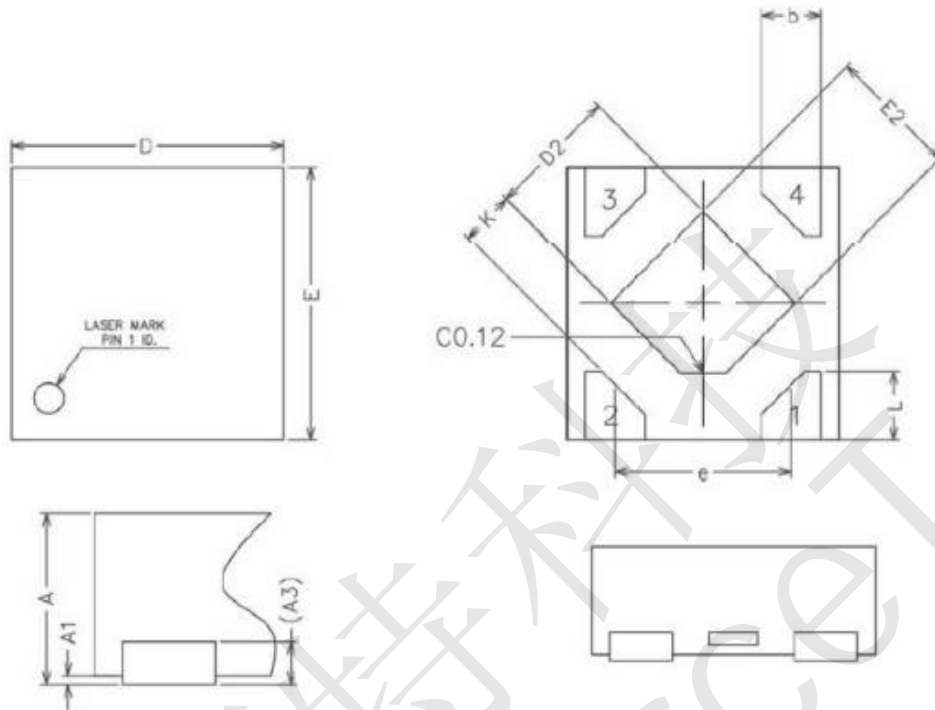

COMMON DIMENSIONS
(UNITS OF MEASURE=MILLIMETER)

SYMBOL	MIN	NOM	MAX
A	0.34	0.37	0.40
A1	0.00	0.02	0.05
A3	0.100REF		
b	0.17	0.22	0.27
D	0.95	1.00	1.05
E	0.95	1.00	1.05
D2	0.43	0.48	0.53
E2	0.43	0.48	0.53
L	0.20	0.25	0.30
e	—	0.65	—
K	0.15	—	—



深圳市矽源特科技有限公司
ShenZhen ChipSourceTek Technology Co.,Ltd.

Shenzhen ChipSourceTek Technology Co., Ltd

ChipSourceTek cannot assume responsibility for use of any circuitry other than circuitry entirely embodied in a ChipSourceTek product. No circuit patent license, copyrights or other intellectual property rights are implied. ChipSourceTek reserves the right to make changes to their products or specifications without notice. Customers are advised to obtain the latest version of relevant information to verify, before placing orders, that information being relied on is current and complete.