



Key Features

- Patent Pending 3 Phase Power Line Shift Charge Pump Eliminates Need for DC-Blocking Capacitors
- TrueCapFree Architecture, Output Biased at 0V (System Ground)
- Excellent Low Frequency Fidelity
- High PSRR
- Less Than 1uA Shutdown Current
- Support Both Fully Differential and Single-Ended Inputs
- Short Circuit and Over Temperature Protection
- Selectable Gain Settings: -6dB, 0dB, 3dB and 6dB
- Available in Space Saving Packages: TQFN3x3-16L

Applications

- Smart Phones/Cellular Phones
- Notebook Computers
- Portable DVD Player
- Personal Digital Assistants (PDAs)
- Electronic Dictionaries
- Digital Still Cameras
- Potable Gaming

General Description

The PAM8908 stereo headphone driver is designed for portable equipment where board space is at a premium. The PAM8908 uses a unique, patent pending architecture to produce a ground-referenced output from a single supply, eliminating the need for large DC-blocking capacitors, saving cost, board space, and component height.

The PAM8908 delivers up to 25mW per channel into a 16Ω load and has low 0.03% THD+N. A high power-supply rejection ratio allows this device to operate from noisy digital supplies without an additional linear regulator.

The PAM8908 operates from a single supply from 2.5V to 5.5V, has short-circuit and over temperature protection. Shutdown mode reduces supply current to less than 1uA.

Typical Application Circuit

Typical Application Configuration with Differential Input Signals

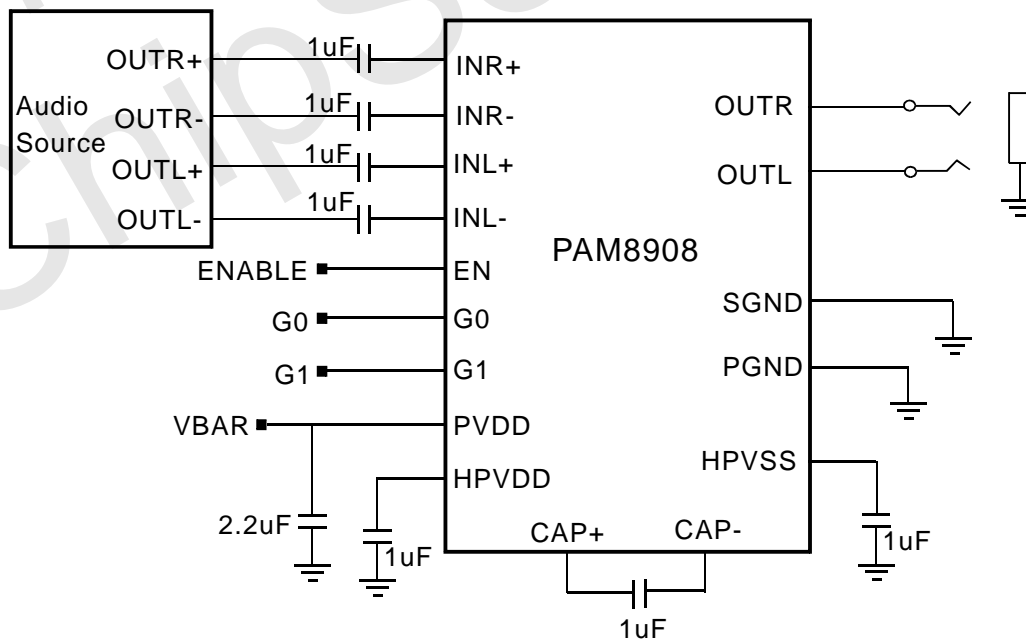



Typical Application Circuit

Typical Application Configuration with Single-Ended Input Signal

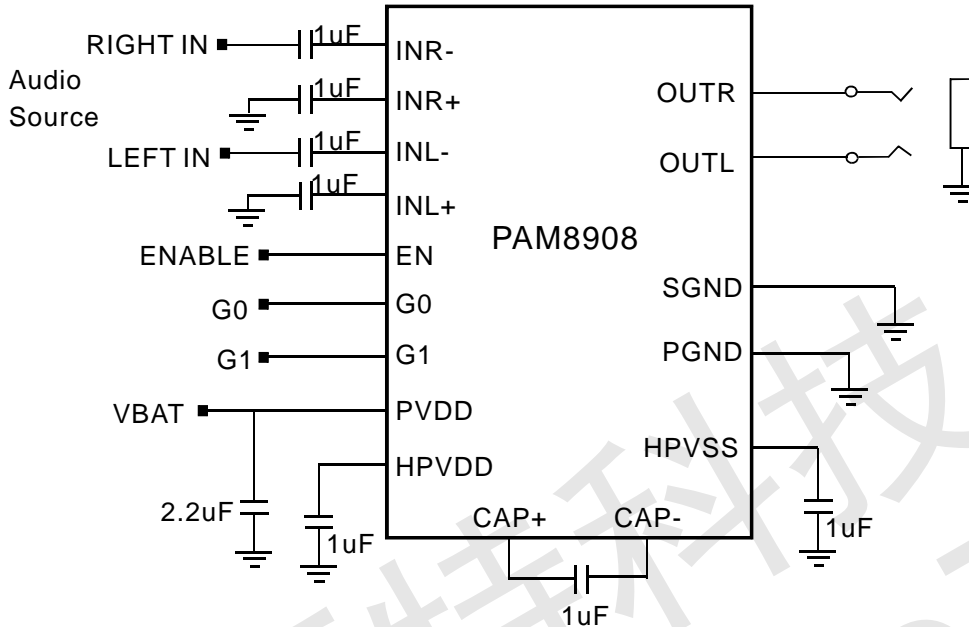

Block Diagram

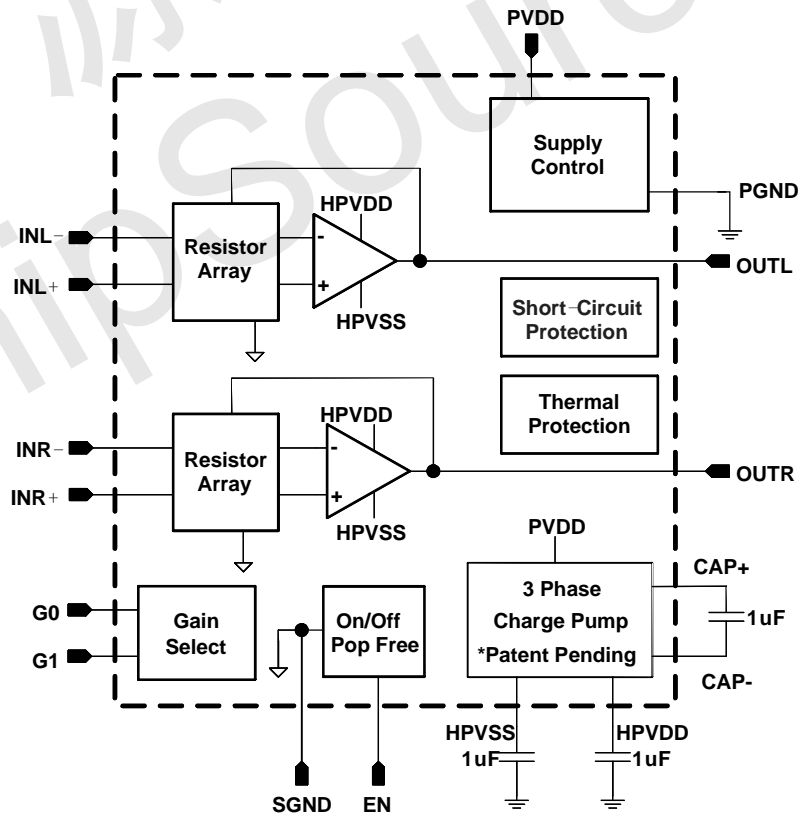



Absolute Maximum Ratings

These are stress ratings only and functional operation is not implied. Exposure to absolute maximum ratings for prolonged time periods may affect device reliability. All voltages are with respect to ground.

Supply Voltage(PVDD).....	6.0V	Storage Temperature.....	-65°C to 150°C
Input Voltage(INR+, INR-, INL+, INL-).....		Maximum Junction Temperature.....	150°C
.....HPVSS-0.3V to HPVDD+0.3V		Soldering Temperature.....	250°C,10 sec
Control Interface Voltage(G0, G1, EN).....			
.....-0.3V to PVDD+0.3V			

Recommended Operating Conditions

Supply Voltage Range.....	2.5V to 5.5V	Ambient Temperature Range.....	-40°C to 85°C
		Junction Temperature Range.....	-40°C to 125°C

Thermal Information

Parameter	Symbol	Package	Maximum	Unit
Thermal Resistance (Junction to Ambient)	θ_{JA}	TQFN 3x3-16	35	°C/W
Thermal Resistance (Junction to Case)	θ_{JC}	TQFN 3x3-16	14	°C/W

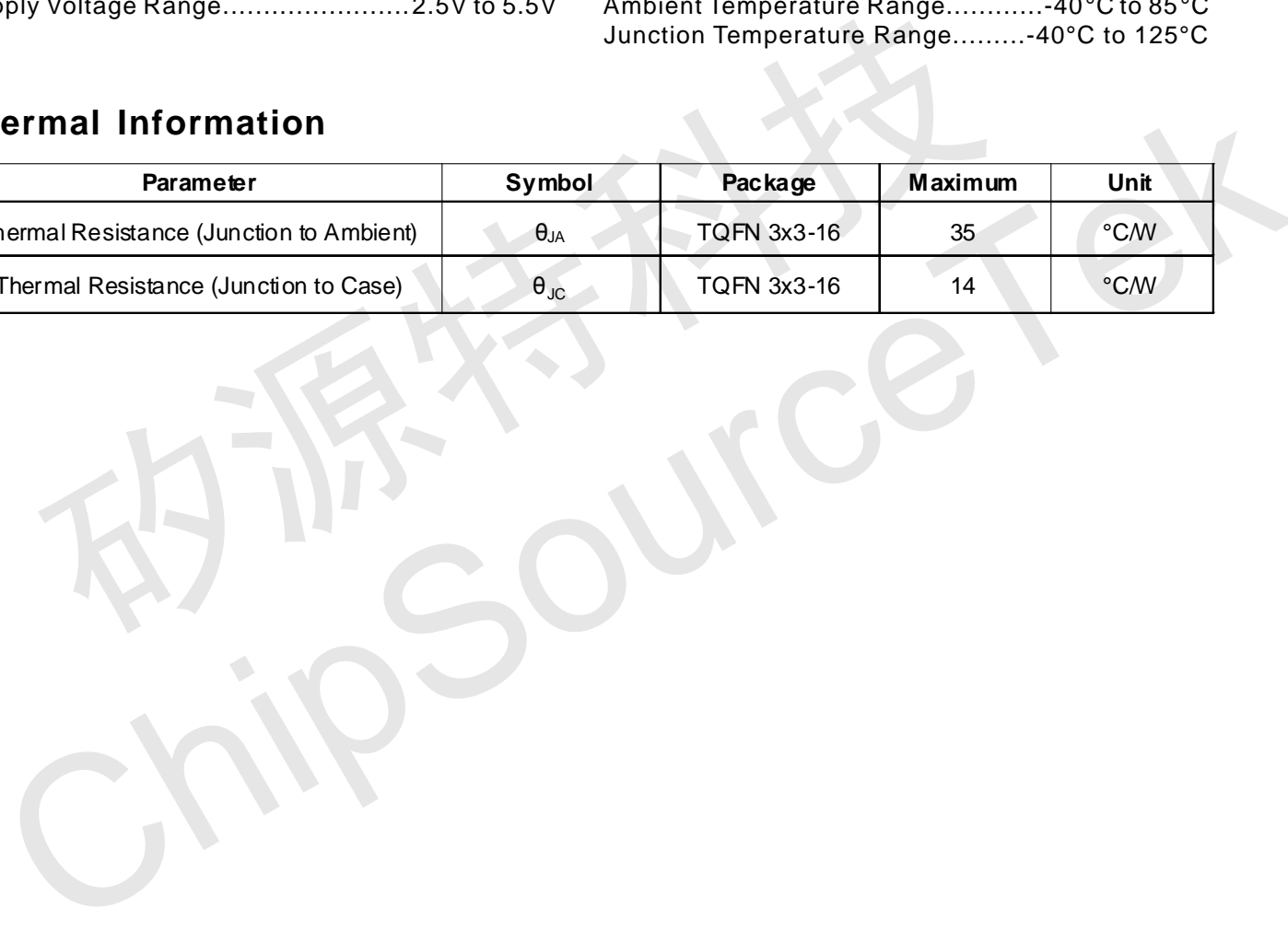



Electrical Characteristic

$T_A=25^{\circ}\text{C}$, $\text{PVDD}=3.6\text{V}$, $\text{RL}=16\Omega$ (unless otherwise noted)

Parameter	Symbol	Test Condition	Min	Typ	Max	Unit
Supply Voltage	PVDD		2.5		5.5	V
Quiescent Current	I _Q	EN=PVDD, No load		4		mA
Output Power per Channel	P _o	THD=1%, f=1kHz, RL=16Ω		35		mW
		THD=1%, f=1kHz, RL=32Ω		25		
Shutdown Current	I _{sd}	EN=0V, PVDD=2.5V to 5.5V		0.1	1	uA
EN High level input voltage	V _{IH}		1.4			V
EN Low level input voltage	V _{IL}				0.6	V
G0,G1 High level input voltage	V _{GH}		1.4			V
G0,G1 Low level input voltage	V _{GL}				0.6	V
Output Offset voltage	V _{os}			1	3	mV
Cbsed-loop voltage gain	A _V	G0=0V, G1=0V		-6		dB
		G0=PVDD, G1=0V		0		dB
		G0=0V, G1=PVDD		3		dB
		G0=PVDD, G1=PVDD		6		dB
Power supply rejection ratio	PSRR	Input AC-GND, f=1KHz, V _{pp} =200mV		75		dB
Total Harmonic distortion plus noise	THD+N	P _o =20mW, f=1kHz		0.03		%
Signal to noise ratio	SNR	P _o =20mW into 16Ω		100		dB
Noise output voltage	E _n	A-weighted		10		uVrms
Corsstalk	CS	P _o =15mW, f=1kHz		80		dB
Chargepump switching frequency	F _{osc}		1.2	1.5	1.8	MHz
start-up time	T _{on}	EN from low to high		0.4		mS
Thermal shutdown	OTP	Threshold		150		°C
Thermal shutdown Hysteresis	OTPH	Hysteresis		20		°C



Typical Operating Characteristics

$T_A=25^{\circ}\text{C}$, $\text{PVDD}=3.6\text{V}$, $f=1\text{kHz}$, $\text{Gain}=6\text{dB}$, unless otherwise.

1. THD+N vs Output Power

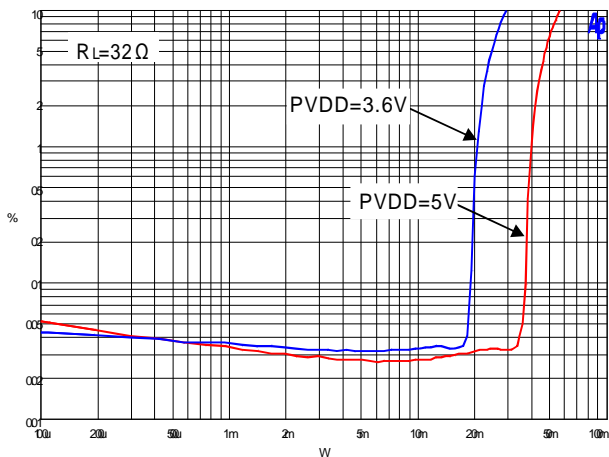

2. THD+N vs Output Power

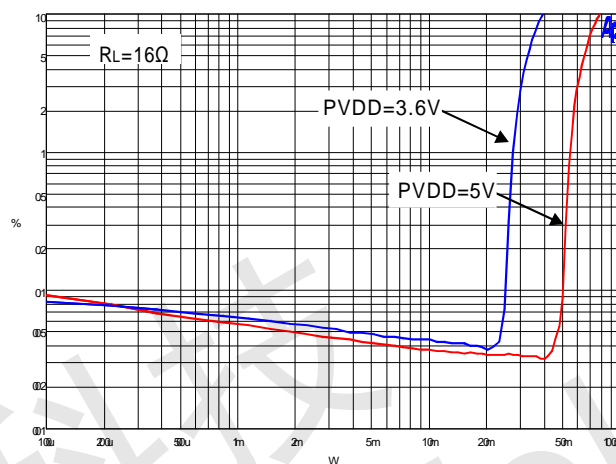

3. THD+N vs Frequency

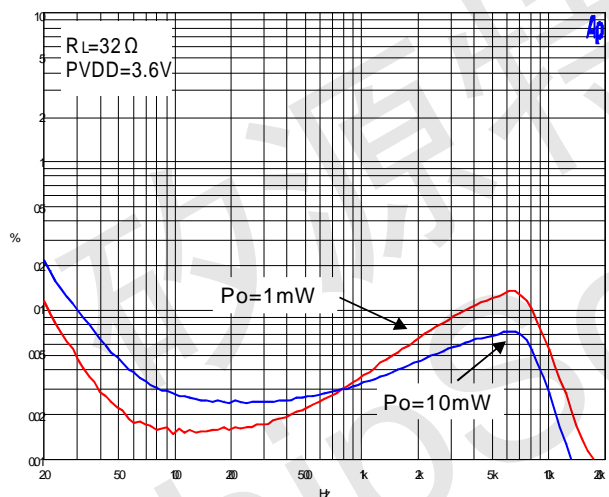

4. THD+N vs Frequency

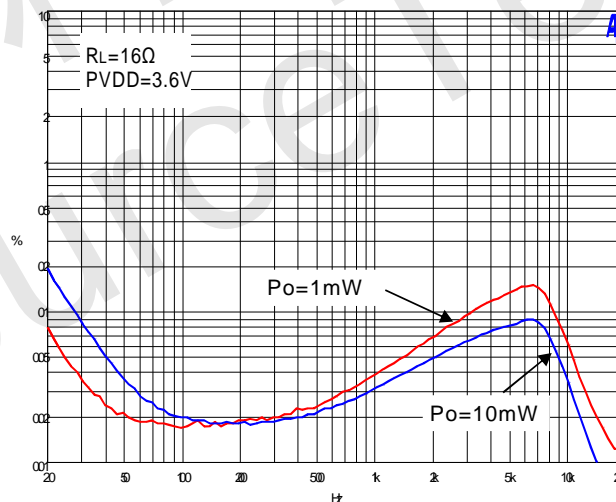

5. Frequency Response

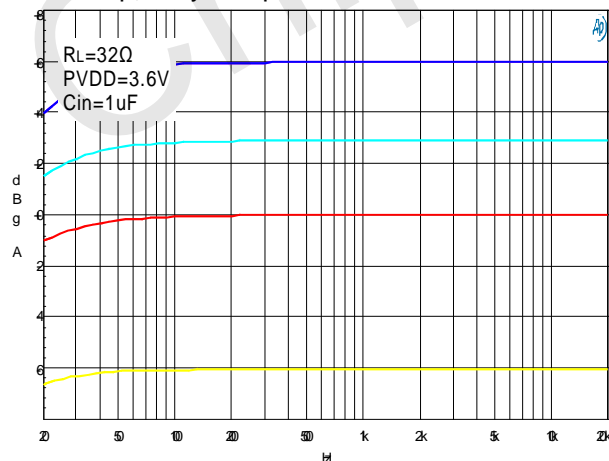

6. Frequency Response

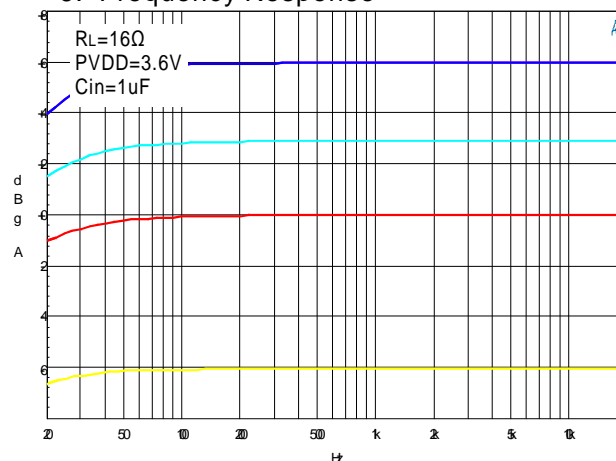



Typical Operating Characteristics

$T_A=25^{\circ}\text{C}$, $\text{PVDD}=3.6\text{V}$, $f=1\text{kHz}$, $\text{Gain}=6\text{dB}$, unless otherwise.

7. Crosstalk

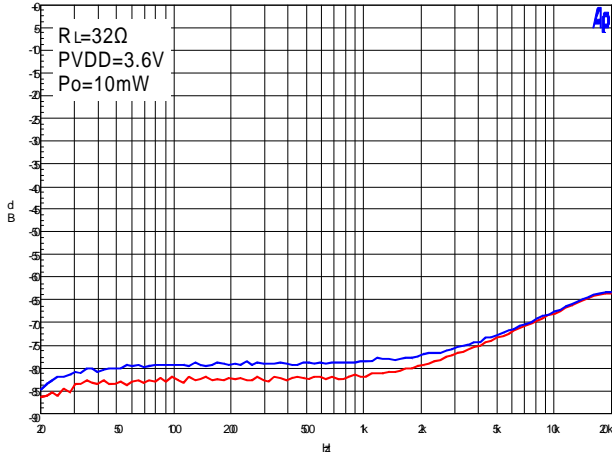

8. Crosstalk

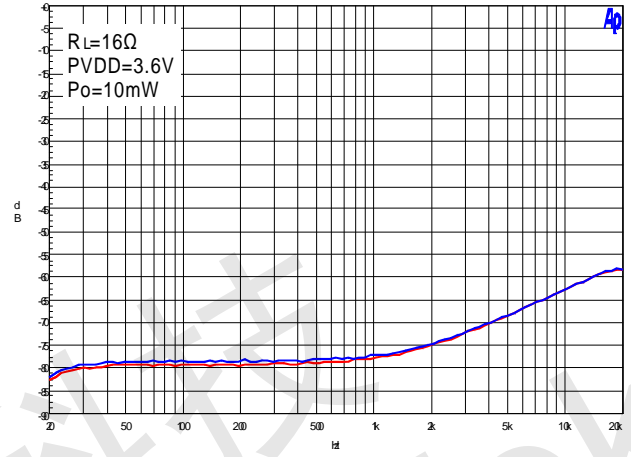

9. PSRR

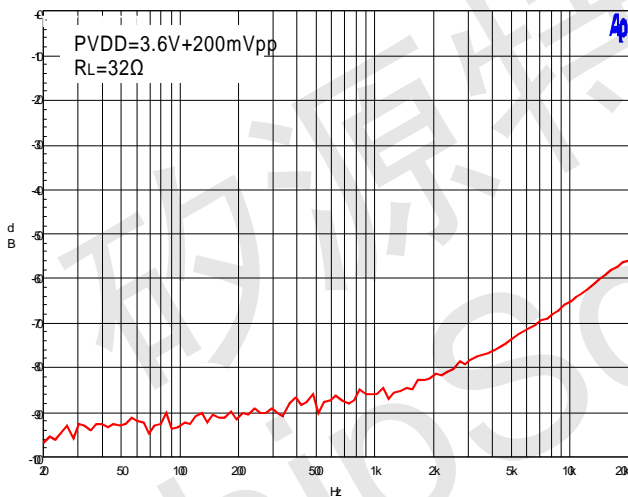

10. PSRR

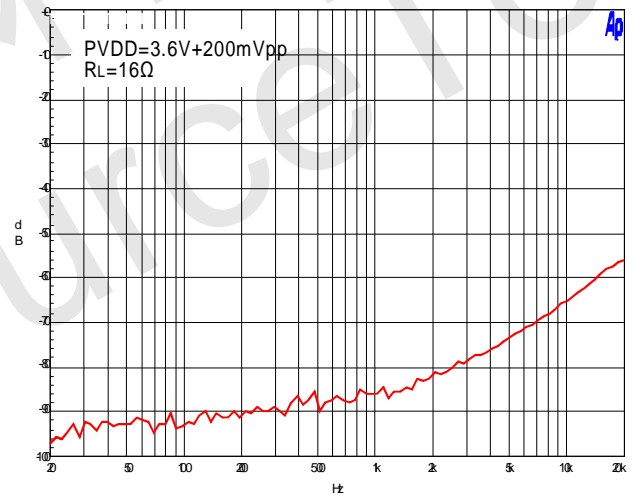

11. FFT Noise

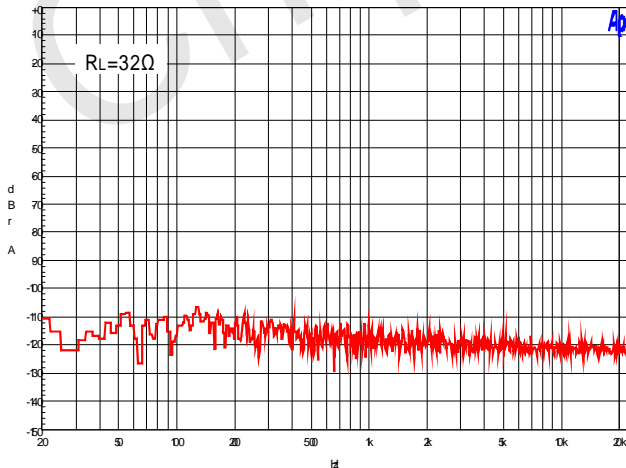

12. FFT Noise

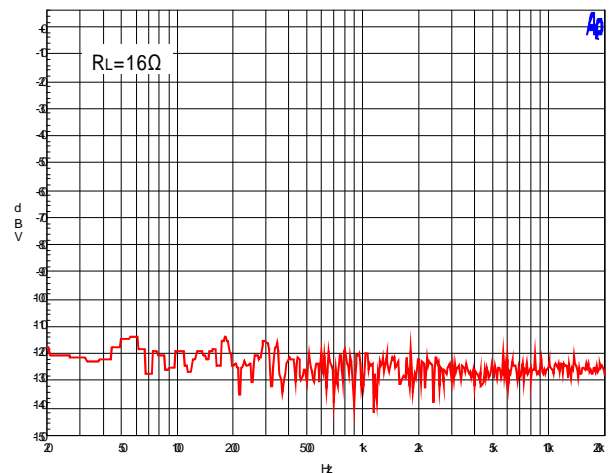



Typical Operating Characteristics

$T_A=25^{\circ}\text{C}$, $\text{PVDD}=3.6\text{V}$, $f=1\text{kHz}$, $\text{Gain}=6\text{dB}$, unless otherwise.

13. Start up with signal

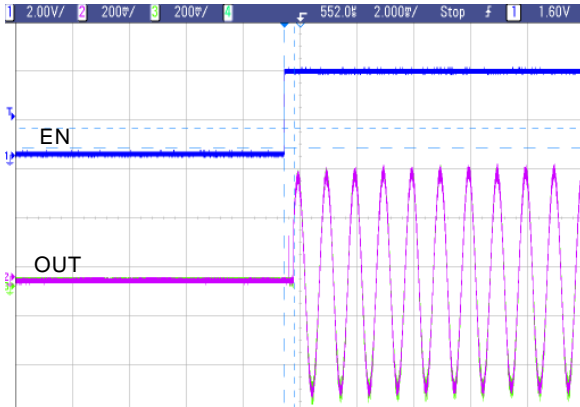

14. Shutdown with signal

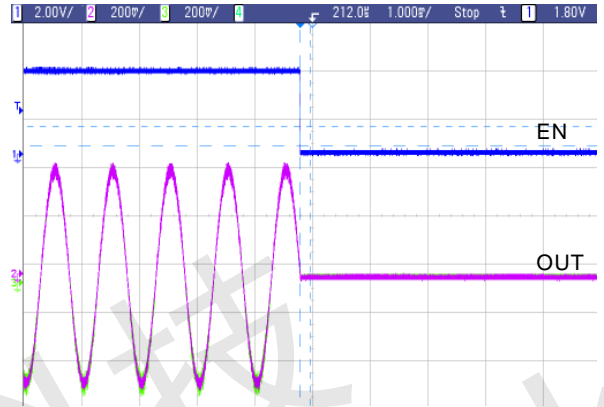

15. Start up without signal

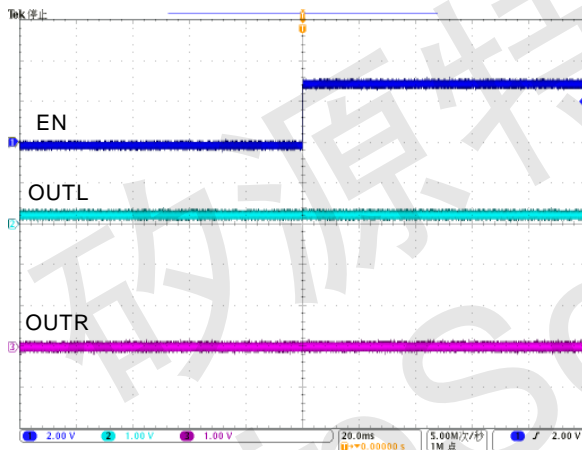

16. Shutdown without signal

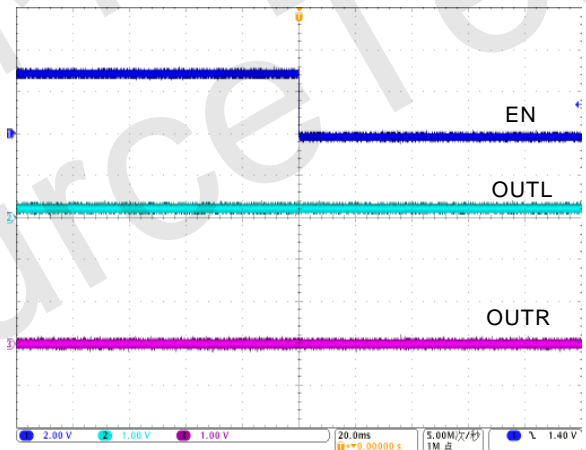



Application Information

The basic PAM8908 application circuit is shown in page 1 and page 2.

GAIN CONTROL

The PAM8908 has four gain settings which are controlled with pins G0 and G1. The following table gives an overview of the gain function.

G0 VOLTAGE	G1 VOLTAGE	AMPLIFIER GAIN
≤0.6 V	≤0.6 V	-6 dB
≥1.4 V	≤0.6 V	0 dB
≤0.6 V	≥1.4 V	3 dB
≥1.4 V	≥1.4 V	6 dB

INPUT COUPLING CAPACITORS

Input coupling capacitors block any DC bias from the audio source and ensure maximum dynamic range. Input coupling capacitors also minimize PAM8908 turn-on pop to an inaudible level.

The input capacitors are in series with PAM8908 internal input resistors, creating a high-pass filter. The following Equation calculates the high-pass filter corner frequency.

$$f_C = \frac{1}{2\pi R_{IN} C_{IN}}$$

The input impedance, R_{IN} , is dependent on device gain. Larger input capacitors decrease the corner frequency. See the following table for input impedance values.

G0 VOLTAGE	G1 VOLTAGE	R_{IN}
≤0.6 V	≤0.6 V	26.4kΩ
≥1.4 V	≤0.6 V	19.8kΩ
≤0.6 V	≥1.4 V	16.5kΩ
≥1.4 V	≥1.4 V	13.2kΩ

For a given high-pass cutoff frequency, the minimum input coupling capacitor is found as:

$$C_{IN} = \frac{1}{2\pi f_C R_{IN}}$$

Example: Design for a 20Hz corner frequency with a PAM8908 gain of +6dB. The input impedance table gives R_{IN} as 13.2kΩ. The C_{IN} Equation shows the input coupling capacitors must be at least 0.6μF to achieve a 20Hz high-pass corner frequency. Choose a 0.68μF standard value capacitor for each PAM8908 input (X5R material or better is required for best performance).

CHARGE PUMP FLYING CAPACITOR, HPVDD CAPACITOR AND HPVSS CAPACITOR

The PAM8908 uses a built-in charge pump to generate a positive and negative voltage supply for the headphone amplifiers. The charge pump flying capacitor connects between CAP+ and CAP-. It transfers charge to generate the positive and negative supply voltage. The HPVDD capacitor or HPVSS capacitor must be at least equal in or larger than value to the flying capacitor to allow maximum charge transfer. Use low equivalent-series-resistance (ESR) ceramic capacitors (X5R material or better is required for best performance) to maximize charge pump efficiency. Typical values are 1μF for the HPVDD, HPVSS and flying capacitors.

POWER SUPPLY DECOUPLING CAPACITORS

The PAM8908 TrueCapFree headphone amplifier requires adequate power supply decoupling to ensure that output noise and total harmonic distortion (THD) remain low. Use good low equivalent-series-resistance (ESR)

ceramic capacitors (X5R material or better is required for best performance). Place a 2.2μF capacitor within 5 mm of the PVDD pin. Reducing the distance between the decoupling capacitor and PVDD minimizes parasitic inductance and resistance, improving PAM8908 supply rejection performance. Use 0402 or smaller size capacitors if possible.

POWER SUPPLY SEQUENCING

Use input coupling capacitors to ensure inaudible turn-on pop. Activate the PAM8908 after all audio sources have been activated and their output voltages have settled. On power-down, deactivate the PAM8908 before deactivating the audio input source. The EN pin controls device shutdown: Set to 0.6 V or lower to deactivate the PAM8908; set to 1.4 V or higher to activate.



Application Information

TRUECAPFREE HEADPHONE AMPLIFIERS

The TrueCapFree amplifier architecture operates from a single supply voltage and uses two internal charge pumps to generate a positive supply and a negative supply rail for the headphone amplifier. The output voltages are centered around 0 V and are capable of positive and negative voltage swings as shown in the following drawing.

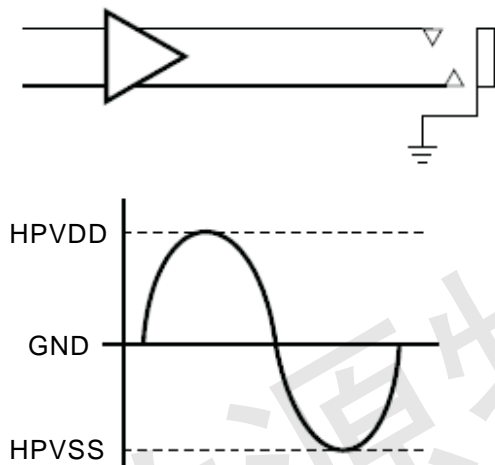

TrueCapFree amplifiers require no output dc-blocking capacitors. The headphone connector shield pin connects to ground and will interface with headphones and non-headphone accessories. The PAM8908 is a TrueCapFree amplifier.

LAYOUT RECOMMENDATIONS

EXPOSED PAD ON PAM8908JR

Solder the exposed metal pad on the PAM8908 TQFN package to the landing pad on the PCB. Connect the landing pad to ground or leave it electrically unconnected(floating). Do not connect the landing pad to PVDD or to any other power supply voltage. If the pad is grounded, it must be connected to the same ground as the PGND pin 9. Soldering the thermal pad is required for mechanical reliability and enhances thermal conductivity of the package.

GND CONNECTIONS

The SGND pin is an input reference and must be connected to the headphone ground connector pin. This ensures no turn-on pop and minimizes output offset voltage. Do not connect more than ± 0.3 V to SGND.

PGND is a power ground. Connect supply decoupling capacitors for PVDD, HPVDD, and HPVSS to PGND.

POWER SUPPLY CONNECTIONS

Connect the supply voltage to the PVDD pin and decouple it with an X5R or better capacitor. Place both PVDD capacitor within 5 mm of PVDD pin on the PAM8908. Ensure that the ground connection of PVDD capacitor has a minimum length return path to the device. Failure to properly decouple the PAM8908 may degrade audio or EMC performance.



Ordering Information

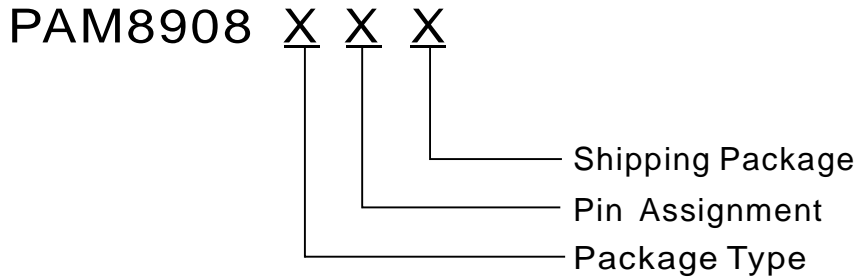

Part Number	Package Type	Shipping Package
PAM8908JER	TQFN3X3-16L	3,000 Units/ Tape & Reel





Outline Dimensions

3x3 mm TQFN 16

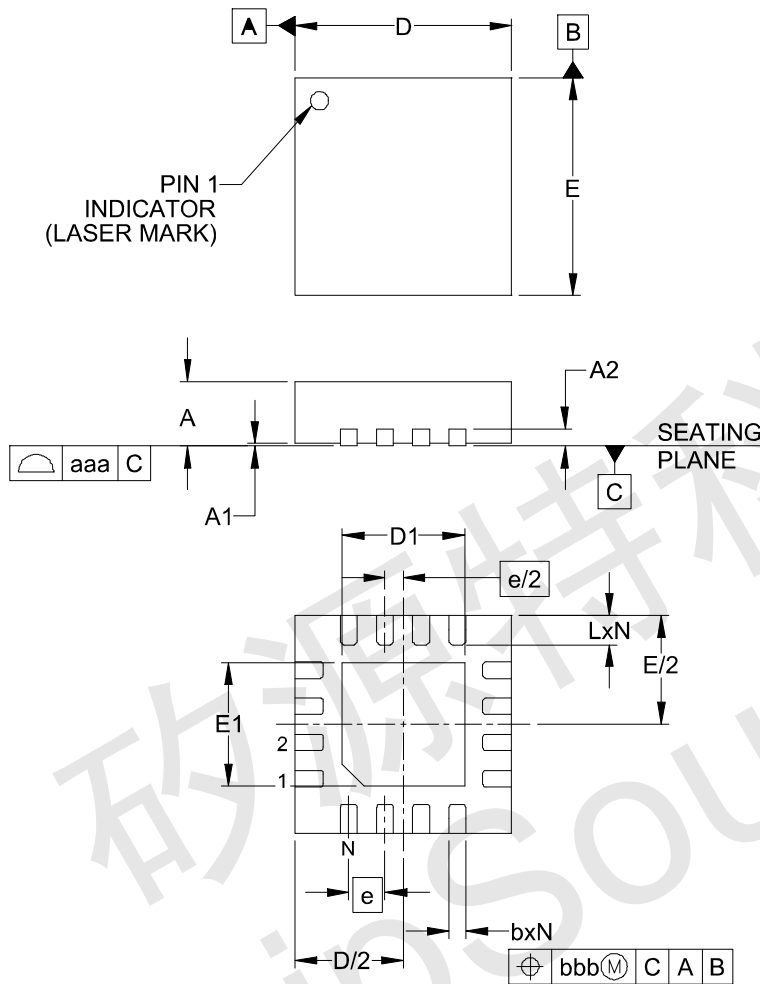

DIMENSIONS (Millimeters)			
	MIN	TYP	MAX
A	0.40	0.50	0.60
A1	0.00	0.02	0.05
A2	0.20		
b	0.18	0.25	0.30
D	2.90	3.00	3.10
D1	1.55	1.70	1.80
E	2.90	3.00	3.10
E1	1.55	1.70	1.80
e	0.50BSC		
L	0.30	0.40	0.50
N	16		
aaa	0.08		
bbb	0.10		

NOTES:

1. CONTROLLING DIMENSIONS ARE IN MILLIMETERS (ANGLES IN DEGREES).
2. COPLANARITY APPLIES TO THE EXPOSED PAD AS WELL AS THE TERMINALS.
3. DAP IS 1.90 x 1.90mm.