

TX4054

Li-Ion battery charger

Features

- Protection of battery cell reverse connection
- Programmable charge current up to 800mA
- No MOSFET sense resistor or blocking diode required
- Complete linear Charger for single Cell Lithium-Ion Batteries
- CC and CV operation with thermal regulation to maximize Rate without risk of overheating
- Preset 4.2V charge voltage with $\pm 1\%$ accuracy
- Automatic Recharge
- C/10 charge termination
- 2.9V trickle current charge threshold
- Soft-Start limits inrush current
- Available in SOT23-5 package

Applications

- Cellular Telephones
- Mobile Power Supply
- Digital Still Cameras
- MP3 Players
- Bluetooth Applications
- Portable Devices
- USB Bus-Powered Chargers

GENERAL DESCRIPTION

TX4054 is a complete CC/CV linear charger for single cell lithium-ion batteries. it is specifically designed to work within USB power Specifications.

No external sense resistor is needed and no blocking diode is required due to the internal P-MOSFET architecture. Thermal feedback regulates the charge current to limit the die temperature during high power operation or high ambient temperature .The charge voltage is fixed at 4.2V, and the charge current can be programmed externally with a single resistor. The TX4054 automatically terminates the charge

cycle when the charge current drops to 1/10th the programmed value TX_{ter} the final float voltage is reached.

When the input supply (wall adapter or USB supply) is removed the TX4054 automatically enters a low current state dropping the battery drain current to less than 2 μ A. The TX4054 can be put into shutdown mode reducing the supply current to 55 μ A.

Other features include Battery temperature monitor, under-voltage lockout, automatic recharge and two status pins to indicate charge and charge termination.

TX4054

Li-Ion battery charger

Pin Configuration

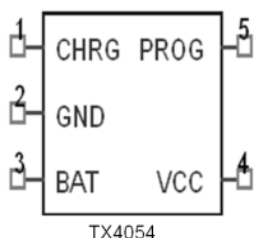

Pin Assignment

PIN Num.	Symbol	Function
1	CHRG	Open-Drain charge status output
2	GND	Ground
3	BAT	Battery connection Pin
4	VCC	Positive input supply voltage
5	PROG	Constant Charge Current Setting and Charge Current Monitor Pin

Absolute Maximum Ratings

Parameter	Rating	Unit
Input supply voltage : Vcc	-0.3~8	V
PROG pin voltage	-0.3~VCC+0.3	V
BAT pin voltage	-0.3~7	V
CHRG pin voltage	-0.3~10	V
BAT pin current	800	mA
PROG pin current	800	uA
Maximum junction temperature	150	°C
Operating ambient temperature	-40~85	°C
Storage temperature	-65~125	°C
Soldering temperature and time	+260 (Recommended 10S)	°C

Caution: The absolute maximum ratings are rated values exceeding which the product could suffer physical damage. These values must therefore not be exceeded under any conditions.

TX4054

Li-Ion battery charger

Electrical Characteristics ($V_{IN} = 5V$; $T_J = 25^\circ C$; unless otherwise specified.)

Symbol	Parameter	Test Condition	MAX	TPY	MIN	Unit
V _{CC}	Input supply voltage		4.0	5.0	8.0	V
I _{CC} -I _{BAT}	Static Current	Charge mode, R _{PROG} =10K		150	500	uA
		Standby mode(charge end)		55	100	uA
		Shutdown mode R _{PROG} not connected, V _{CC} <V _{BAT} ,or V _{CC} <V _{UV})		20	40	uA
V _{FLOAT}	Regulated output voltage	0°C≤T _A ≤85°C I _{BAT} =40mA	4.158	4.2	4.242	V
I _{BAT}	BAT pin current (The condition of current mode is V _{BAT} =3.9V)	R _{PROG} =2.6K, current mode	525	550	575	mA
		Standby mode: V _{BAT} =4.2V	0	-2.5	-6.0	uA
		Shutdown mode, R _{PROG} not connected		-/+1 %	-/+5%	uA
		Sleep mode, V _{CC} =0V		-1	-2	uA
I _{TRIKL}	Trickle charge current	V _{BAT} <V _{TRIKL} , R _{PROG} =10K	8	10	12	mA
V _{TRIKL}	Trickle charge threshold voltage	R _{PROG} =10K, V _{BAT} rising	2.8	2.9	3.0	V
V _{TRHYS}	Trickle voltage hysteresis voltage	R _{PROG} =10K	150	200	250	mV
V _{UV}	V _{CC} under voltage lockout threshold	V _{CC} from low to high	3.5	3.7	3.9	V

Electrical Characteristics ($V_{IN} = 5V$; $T_J = 25^\circ C$; unless otherwise specified.)

V _{UVHYS}	V _{CC} under voltage lockout hysteresis		150	200	300	mV
V _{ASD}	V _{CC} -V _{BAT} lockout threshold voltage	V _{CC} from low to high	100	140	180	mV
		V _{CC} from high to low	50	80	110	mV
I _{TERM}	C/10 termination current threshold	R _{PROG} =2.6K	60	70	80	mA
V _{PROG}	PROG pin voltage	R _{PROG} =10K, current mode	0.9	1.0	1.1	V
V _{CHRG}	CHARGE Pin output low voltage	I _{CHRG} =5mA		0.3	0.6	V
$\Delta V_{RECHARGE}$	Recharge battery threshold voltage	V _{FLOAT} -V _{RECHRG}	120	180	240	mV

TX4054 ***Li-Ion battery charger***

$R_{DS(ON)}$	The resistance of power FET "ON" (between VCC and BAT)			650		mΩ
T_{SS}	Soft-start time	$I_{BAT}=0$ to $I_{BAT}=1300V/R_{PROG}$		20		μS
$T_{RECHARGE}$	Recharge comparator filter time	V_{BAT} from high to low	0.8	1.8	4	mS
I_{PROG}	PROG pin pull-up current			2.0		μA

Description of the Principle

The TX4054 is a complete CC/CV linear charger for single cell lithium-ion batteries. CC/CV to charger batter by internal MOSFET .It can deliver up to 800mA of charge current .No blocking diode or external current sense resistor is required.TX4054 include Open-Drain charge status Pins: Charge status indicator CHRГ.

The internal thermal regulation circuit reduces the programmed charge current if the die temperature attempts to rise above a preset value of approximately 145 °C . This feature protects theTX4054 from excessive temperature, and allows the user to push the limits of the power handling capability of a given circuit board without risk of damaging theTX4054 or the external components. Another benefit of adopting thermal regulation is that charge current can be set according to typical, not worst-case, ambient temperatures for a given application with the assurance that the charger will automatically reduce the current in worst-case conditions.

The charge cycle begins when the voltage at the VCC pin rises above the UVLO level, a current set resistor is connected from the PROG pin to ground, The CHRГ pin outputs a logic low to indicate that the charge cycle is on going. At the beginning of the charge cycle, if the battery voltage is below 2.9V, the charge is in precharge mode to bring the cell voltage up to a sTXe level for charging. The charger goes into the fast charge CC mode once the voltage on the BAT pin rises above 2.9 V. In CC mode, the charge current is set by RPROG. When the battery approaches the regulation voltage 4.2V, the charge current begins to decrease as theTX4054 enters the CV mode. When the current drops to charge termination threshold, the charge cycle is terminated, and CHRГ pin assumes a high impedance state to indicate that the charge cycle is terminated.The charge termination threshold is 10% of the current in CC mode. The charge cycle can also be automatically restarted if the BAT pin voltage falls below the recharge threshold. The on-chip reference voltage, error amplifier and the resistor divider provide regulation voltage with 1% accuracy which can meet the requirement of lithium-ion and lithium polymer batteries. When the input voltage is not present, or input voltage is below V_{BAT} , the charger goes into a sleep mode, dropping battery drain current to less than 3μA. This greatly reduces the current drain on the battery and increases the standby time. The charging profile is shown in the following figure:

TX4054 **Li-Ion battery charger**

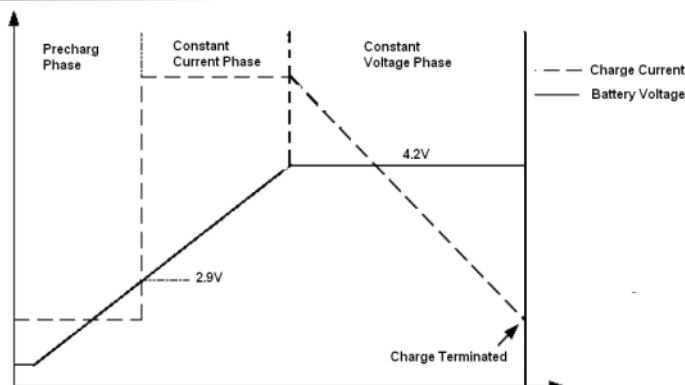

Programming Charge Current

The charge current is programmed using a single resistor from the PROG pin to ground. The program resistor and the charge current are calculated using the following equations.

$$R_{PROG} = \frac{1450}{I_{BAT}};$$

In application, according to the charge current to determine R_{PROG} , the relation between R_{PROG} and charge current can reference the following chart:

R_{PROG} (K)	I_{BAT} (mA)
24K	60
12K	120
6K	240
4K	363
3K	483
2.6K	555

Charge Termination

A charge cycle is terminated when the charge current falls to 1/10th the programmed value TX_{ter} the final float voltage is reached. This condition is detected by using an internal filtered comparator to monitor the PROG pin. When the PROG pin voltage falls below 100mV for longer than t_{TEMP} (typically 1.8mS), Charging is terminated. The charge current is latched off and the TX4054 enters standby mode, where the input supply current drops to 55μA (**Note: C/10 termination is disabled in trickle charging and thermal limiting modes**).

When charging, transient loads on the BAT pin can cause the PROG pin to fall below 100mV for short periods of time before the DC charge current has dropped to 1/10th the programmed value. The 1.8mS filter time (t_{TEMP}) on the termination comparator ensures that transient loads of this nature do not result in premature charge cycle termination. Once the average charge current drops below 1/10th the programmed value, the TX4054 terminated the charge cycle and ceases to provide any current through the BAT pin. In this state all loads on the BAT pin must be supplied by the battery.

TX4054 *Li-Ion battery charger*

The TX4054 constantly monitors the BAT pin voltage in standby mode. If this voltage drops below the 4.10V recharge threshold (V_{RECHRG}), another charge cycle begins and current is once again supplied to the battery. To manually restart a charge cycle when in standby mode, the input voltage must be removed and reapplied or the charger must be shut down and restarted using the PROG pin. Figure 1 shows the state diagram of a typical charge cycle

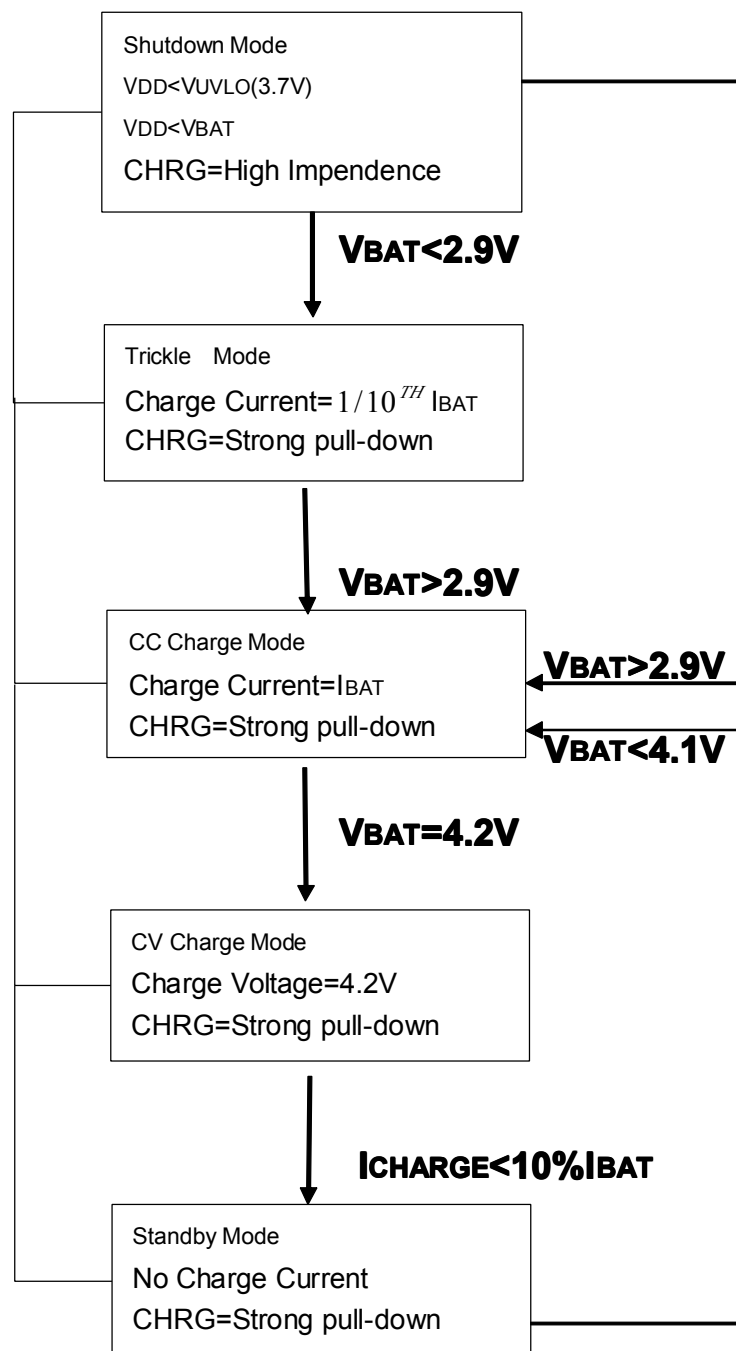

Fig.1 State diagram of a typical charge cycle

TX4054

Li-Ion battery charger

Thermal limiting

An internal thermal feedback loop reduces the programmed charge current if the die temperature attempts to rise above a preset value of approximately 145 °C . The feature protects the TX4054 from excessive temperature and allows the user to push the limits of the power handling capability of a given circuit board without risk of damaging the TX4054. The charge current can be set according to typical (not worst-case) ambient temperature with the assurance that the charger will automatically reduce the current in worst-case conditions.

Under Voltage lockout (UVLO)

An internal under voltage lockout circuit monitors the input voltage and keeps the charger in shutdown mode until V_{CC} rises above the under voltage lockout threshold . If the UVLO comparator is tripped, the charger will not come out of shutdown mode until V_{CC} rises 140mV above the battery voltage.

Auto restart

Once charge is been terminated, TX4054 immediately use a 1.8ms filter time ($t_{RECHARGE}$) on the termination comparator to constant monitor the voltage on BAT pin. If this voltage drops below the 4.1V recharge threshold (about between 80% and 90% of V_{CC}), another charge cycle begins. This ensured the battery maintained (or approach) to a charge full status and avoid the requirement of restarting the periodic charging cycle. In the recharge cycle, CHR_G pin enters a pulled down status.

Stability Considerations

In CC mode, the PROG pin is in the feedback loop, not the battery. The CC mode stability is TXfected by the impedance at the PROG pin. With no additional capacitance on the PROG pin, the charger is stable with program resistor values as high as 20K. However, additional capacitance on this node reduces the maximum allowed program resistor. Therefore, if I_{PROG} pin is loaded with a capacitance C, the following equation should be used to calculate the maximum resistance value for R_{PROG}:

$$R_{PROG} \leq \frac{1}{2\pi \times 10^5 \times C_{PROG}}$$

As user, may think charge current is important, not instantaneous current. For example, to run a low current mode switch power which parallel connected with battery, the average current from BAT pin usually importance to instantaneous current. In this case, In order to measure average charge current or isolate capacitive load from I_{PROG} pin, a simple RC filter can be used on PROG pin as shown in Figure 2. In order to ensure the stability add a 10K resistor between PROG pin and filter capacitor.

TX4054

Li-Ion battery charger

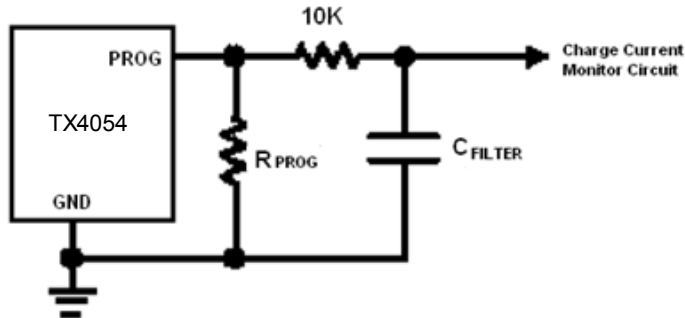

Fig.2 Isolating with capacitive load on PROG Pin

Power Dissipation

The conditions that cause the TX4054 to reduce charge current through thermal feedback can be approximated by considering the power dissipated in the IC. Nearly all of this power dissipation is generated by the internal MOSFET-this is calculated to be approximately:

$P_D = (V_{CC} - V_{BAT}) \times I_{BAT}$ The approximate ambient temperature at which the thermal feedback begins to protect the IC is:

$$T_A = 145^\circ C - P_D \times \theta_{JA}; \quad \text{So: } T_A = 145^\circ C - (V_{CC} - V_{BAT}) \times I_{BAT} \times \theta_{JA}$$

For example: The TX4054 with 5V supply voltage through programmable provides full limiting current 550mA to a charge lithium-ion battery with 3.85V voltage. If θ_{JA} is $120^\circ C/W$ (reference to PCB layout considerations), When TX4054 begins to decrease the charge current, the ambient temperature about:

$$T_A = 145 - (5 - 3.85) \times 0.55 \times 120 = 69.1^\circ C$$

TX4054 can work in the condition of the temperature is above $69.1^\circ C$, but the charge current will pull down to below 550mA. In a fixed ambient temperature, the charge current is calculated to be approximately :

$$I_{BAT} = \frac{145^\circ C - T_A}{(V_{CC} - V_{BAT}) \times \theta_{JA}}$$

Just as Description of the Principle part talks about so, the current on PROG pin will reduce in proportion to the reduced charge current through thermal feedback. In TX4054 design applications don't need to considerate the worst case of thermal condition, this point is importance, because if the junction temperature up to $145^\circ C$, TX4054 will auto reduce the power dissipation.

TX4054

Li-Ion battery charger

Thermal Considerations

Because of the small size of the thin SOT23-5 package, it is important to use a good thermal PC board layout to maximize the available charge current. The PC board copper is the heat sink. The footprint copper pads should be as wide as possible and expand out to larger copper areas to spread and dissipate the heat to the surrounding ambient. Other heat sources on the board, not related to the charger, must also be considered when designing a PC board layout because they will affect overall temperature rise and the maximum charge current.

VCC bypass capacitor

Many types of capacitors can be used for input bypassing, however, caution must be exercised when using multilayer ceramic capacitors. Because of the self-resonant and high Q characteristics of some types of ceramic capacitors, high voltage transients can be generated under some start-up conditions, such as connecting the charger input to a live power source. Adding a 1.5Ω resistor in series with a ceramic capacitor will minimize start-up voltage transients.

Charging Current Soft Start

TX4054 includes a soft start circuit which used to maximize to reduce the surge current in the beginning of charge cycle. When restart a new charge cycle, the charging current ramps up from 0 to the full charging current within 20μs. In the start process it can maximize to reduce the action which caused by surge current load.

Board Layout Considerations

R_{PROG} at PROG pin should be as close to TX4054 as possible, also the parasitic capacitance at PROG pin should be kept as small as possible.

The capacitance at VCC pin and BAT pin should be as close to TX4054 as possible.

It is very important to use a good thermal PC board layout to maximize charging current. The thermal path for the heat generated by the IC is from the die to the copper lead frame through the package lead (especially the ground lead) to the PC board copper, the PC board copper is the heat sink. The footprint copper pads should be as wide as possible and expand out to larger copper areas to spread and dissipate the heat to the surrounding ambient. Feed through vias to inner or backside copper layers are also useful in improving the overall thermal performance of the charger. Other heat sources on the board, not related to the charger, must also be considered when designing a PC board layout because they will affect overall temperature rise and the maximum charge current.

The ability to deliver maximum charge current under all conditions require that the exposed metal pad on the back side of the TX4054 package be soldered to the PC board ground. Failure to make the thermal contact between the exposed pad on the backside of the package and the copper board will result in larger thermal resistance.

Typical Application

TX4054

Li-Ion battery charger

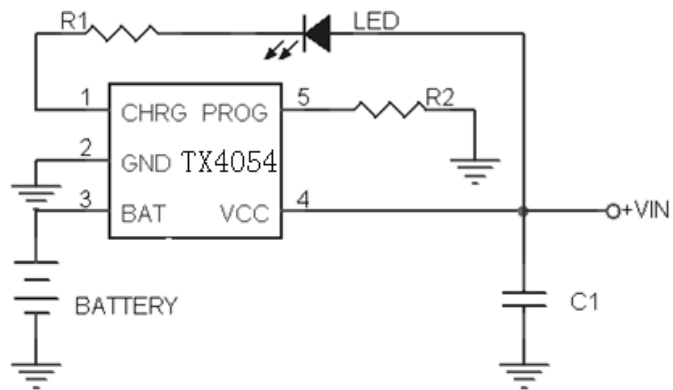

Package Information

5-pin SOT23-5L Outline Dimensions

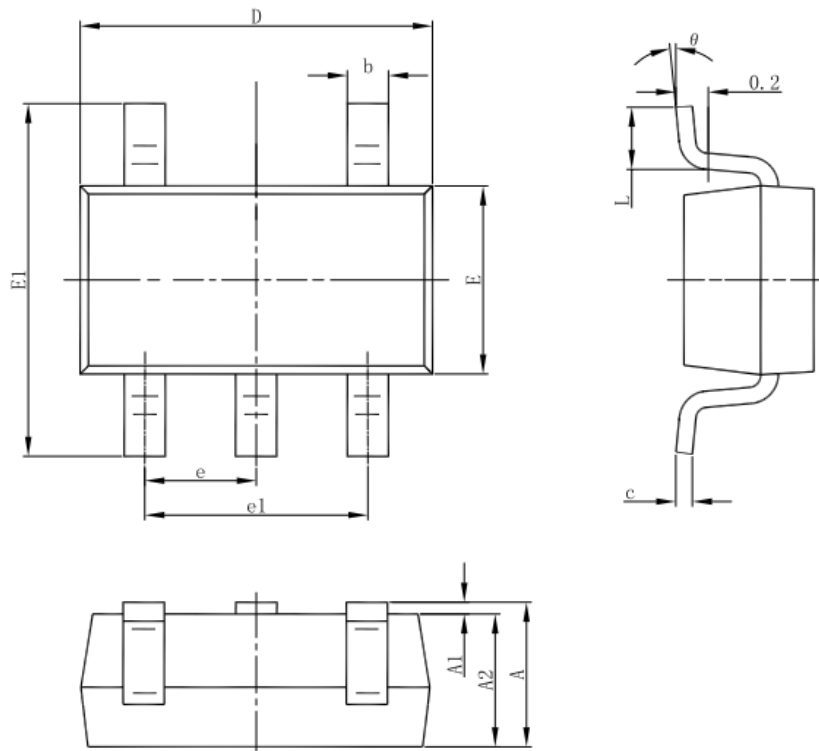

TX4054
Li-Ion battery charger

Symbol	Dimensions In Millimeters		Dimensions In Inches	
	Min	Max	Min	Max
A	1.050	1.250	0.041	0.049
A1	0.000	0.100	0.000	0.004
A2	1.050	1.150	0.041	0.045
b	0.300	0.500	0.012	0.020
c	0.100	0.200	0.004	0.008
D	2.820	3.020	0.111	0.119
E	1.500	1.700	0.059	0.067
E1	2.650	2.950	0.104	0.116
e	0.950(BSC)		0.037(BSC)	
e1	1.800	2.000	0.071	0.079
L	0.300	0.600	0.012	0.024
θ	0°	8°	0°	8°

TX4054
Li-Ion battery charger

© Shanghai TX Electronics Sci-Tech Co., Ltd

TX cannot assume responsibility for use of any circuitry other than circuitry entirely embodied in a TX product. No circuit patent license, copyrights or other intellectual property rights are implied. TX reserves the right to make changes to their products or specifications without notice. Customers are advised to obtain the latest version of relevant information to verify, before placing orders, that information being relied on is current and complete.